



**COMMONWEALTH OF PENNSYLVANIA
DEPARTMENT OF ENVIRONMENTAL PROTECTION
AIR QUALITY PROGRAM**

TITLE V/STATE OPERATING PERMIT

Issue Date: January 28, 2021

Effective Date: January 28, 2021

Expiration Date: January 27, 2026

In accordance with the provisions of the Air Pollution Control Act, the Act of January 8, 1960, P.L. 2119, as amended, and 25 Pa. Code Chapter 127, the Owner, [and Operator if noted] (hereinafter referred to as permittee) identified below is authorized by the Department of Environmental Protection (Department) to operate the air emission source(s) more fully described in this permit. This Facility is subject to all terms and conditions specified in this permit. Nothing in this permit relieves the permittee from its obligations to comply with all applicable Federal, State and Local laws and regulations.

The regulatory or statutory authority for each permit condition is set forth in brackets. All terms and conditions in this permit are federally enforceable applicable requirements unless otherwise designated as "State-Only" or "non-applicable" requirements.

TITLE V Permit No: 15-00015

Federal Tax Id - Plant Code: 23-0960890-4

Owner Information

Name: ARKEMA INC
Mailing Address: 502 THOMAS JONES WAY
EXTON, PA 19341-2530

Plant Information

Plant: ARKEMA INC/WEST CHESTER
Location: 15 Chester County 15003 West Chester Borough
SIC Code: 2821 Manufacturing - Plastics Materials And Resins

Responsible Official

Name: KANISHKA MAPA
Title: PLANT MGR
Phone: (610) 344 - 2810

Permit Contact Person

Name: MIKE MACHESKI
Title: HES MGR
Phone: (610) 344 - 2820

[Signature] _____
JAMES D. REBARCHAK, SOUTHEAST REGION AIR PROGRAM MANAGER



SECTION A. Table of Contents

Section A. Facility/Source Identification

Table of Contents
Site Inventory List

Section B. General Title V Requirements

- #001 Definitions
- #002 Prohibition of Air Pollution
- #003 Property Rights
- #004 Permit Expiration
- #005 Permit Renewal
- #006 Transfer of Ownership or Operational Control
- #007 Inspection and Entry
- #008 Compliance Requirements
- #009 Need to Halt or Reduce Activity Not a Defense
- #010 Duty to Provide Information
- #011 Reopening and Revising the Title V Permit for Cause
- #012 Reopening a Title V Permit for Cause by EPA
- #013 Operating Permit Application Review by the EPA
- #014 Significant Operating Permit Modifications
- #015 Minor Operating Permit Modifications
- #016 Administrative Operating Permit Amendments
- #017 Severability Clause
- #018 Fee Payment
- #019 Authorization for De Minimis Emission Increases
- #020 Reactivation of Sources
- #021 Circumvention
- #022 Submissions
- #023 Sampling, Testing and Monitoring Procedures
- #024 Recordkeeping Requirements
- #025 Reporting Requirements
- #026 Compliance Certification
- #027 Operational Flexibility
- #028 Risk Management
- #029 Approved Economic Incentives and Emission Trading Programs
- #030 Permit Shield
- #031 Reporting
- #032 Report Format

Section C. Site Level Title V Requirements

- C-I: Restrictions
- C-II: Testing Requirements
- C-III: Monitoring Requirements
- C-IV: Recordkeeping Requirements
- C-V: Reporting Requirements
- C-VI: Work Practice Standards
- C-VII: Additional Requirements
- C-VIII: Compliance Certification
- C-IX: Compliance Schedule

Section D. Source Level Title V Requirements

- D-I: Restrictions
- D-II: Testing Requirements
- D-III: Monitoring Requirements
- D-IV: Recordkeeping Requirements
- D-V: Reporting Requirements



SECTION A. Table of Contents

D-VI: Work Practice Standards
D-VII: Additional Requirements

Note: These same sub-sections are repeated for each source!

Section E. Source Group Restrictions

E-I: Restrictions
E-II: Testing Requirements
E-III: Monitoring Requirements
E-IV: Recordkeeping Requirements
E-V: Reporting Requirements
E-VI: Work Practice Standards
E-VII: Additional Requirements

Section F. Alternative Operating Scenario(s)

F-I: Restrictions
F-II: Testing Requirements
F-III: Monitoring Requirements
F-IV: Recordkeeping Requirements
F-V: Reporting Requirements
F-VI: Work Practice Standards
F-VII: Additional Requirements

Section G. Emission Restriction Summary

Section H. Miscellaneous

**SECTION A. Site Inventory List**

Source ID	Source Name	Capacity/Throughput	Fuel/Material
031	CLEAVER BROOKS (B-901)	14.600 MMBTU/HR	
		104.290 Gal/HR	#2 Oil
		13.900 MCF/HR	Natural Gas
032	CLEAVER BROOKS (B-902)	14.700 MMBTU/HR	
		104.290 Gal/HR	#2 Oil
		13.900 MCF/HR	Natural Gas
037	BOILER (B-904)	9.850 MMBTU/HR	
		9.310 MCF/HR	Natural Gas
		68.400 Gal/HR	#2 Oil
110	STRIPPING/HIVAC ON PAD A	N/A	ACRYL/MON/SOLV.
111	STRIPPING (S-207) PAD C	4,000.000 Lbs/HR	ACRYL/MON/SOLV/
112	STRIPPING (S-212) PAD C	4,000.000 Lbs/HR	ACRYL/MON/SOLV.
115	STRIPPING (S-1101) PAD H	10,000.000 Lbs/HR	ACRYL/MON/SOLV.
117	UTILITY VACUUMS		
124	FUGITIVE VOC EMISSIONS		
201	ESTERIFICATION - PAD C (R201, R202, R204, R205)	N/A	ACRYL/MON/SOLV.
202	ESTERIFICATION - PAD A (R150, R151, R154, R155)	N/A	ACRYL/MON/SOLV.
203	ESTERIFICATION - PAD H (R1101, R1151, R1171)	11,100.000 Lbs/HR	ACRYL/MON/SOLV.
734	FIRE PUMP	1.300 MMBTU/HR	
		9.300 Gal/HR	#2 Oil
735	EMERGENCY GENERATOR (DETROIT DIESEL)	4.600 MMBTU/HR	
		33.200 Gal/HR	#2 Oil
736	EMERGENCY GENERATOR (CUMMINS)	4.400 MMBTU/HR	
		29.100 Gal/HR	#2 Oil
C01	REACTOR SEC CONDENSER (C-203)		
C05	REACTOR SEC CONDENSER (C-162)		
C10	STRIPPING OP SEC CONDENSER (C-131)		
C11	STRIPPING OP SEC CONDENSER (C-221)		
C110	STRIPPING OP PRIM CONDENSER (C-157)		
C111	STRIPPING OP PRIM CONDENSER (C-207)		
C112	STRIPPING OP PRIM CONDENSER (C-212)		
C115	STRIPPING OP PRIM CONDENSER (C-1103)		
C12	STRIPPING OP SEC CONDENSER (C-231)		
C14	REACTOR TERT CONDENSER (C-1106)		
C15	STRIPPING OP TERT CONDENSER (C-1105)		
C153	STRIPPING OP PRIM CONDENSER (C-156A)		
C154	STRIPPING OP SEC CONDENSER (C-160)		
C159	STRIPPING OP PRIM CONDENSER (C-149)		
C16	STRIPPING OP SEC CONDENSER (C1104)		
C930	VILTER REFRIGERATED CONDENSER	N/A	PROCESS GAS
CV118A	CONSERVATION VENT FOR W-206		

**SECTION A. Site Inventory List**

Source ID	Source Name	Capacity/Throughput	Fuel/Material
CV160	WASHER CONSERV VENTS (MULTIPLE)		
CV161	CONSERVATION VENT FOR W-1101		
001	NATURAL GAS PIPE LINE		
002	ABOVEGROUND STORAGE TANK		
S01	STACK 1		
S037	STACK 37		
S05	STACK 5		
S10	STACK 10		
S11	STACK 11		
S12	STACK 12		
S14	STACK 14		
S15	STACK 15		
S18	UTILITY VACUUM STACK		
S19	FIRE PUMP STACK		
S20	EMERGENCY GENERATOR STACK		
S31	STACK 31		
S32	STACK 32		
S736	CUMMINS EMER GEN STACK		
S930	VILTER REFRIGERATED CONDENSER STACK		
Z24	FUGITIVE EMISSIONS		

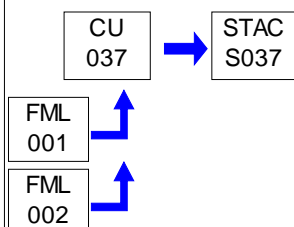
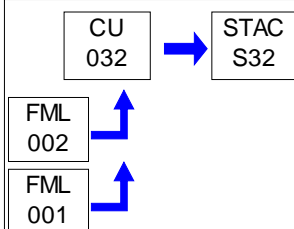
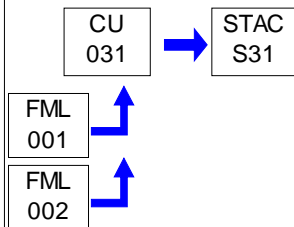
PERMIT MAPS



PERMIT MAPS

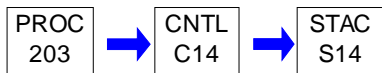
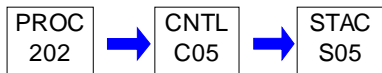
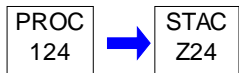
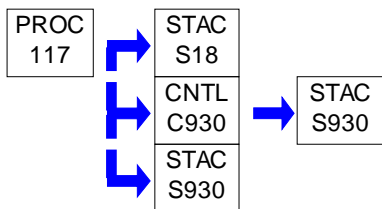
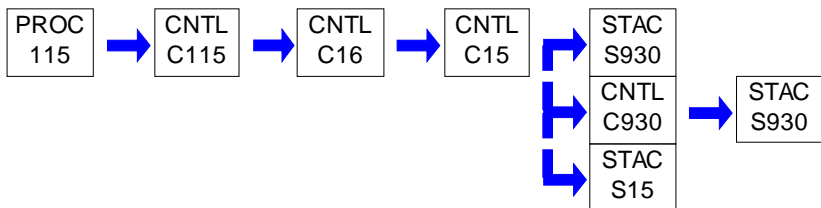
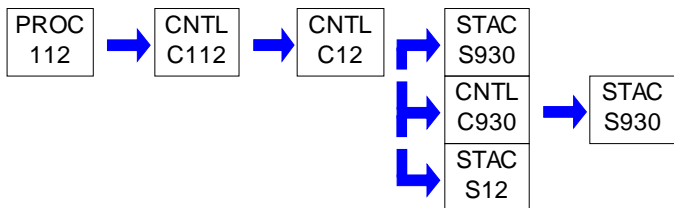
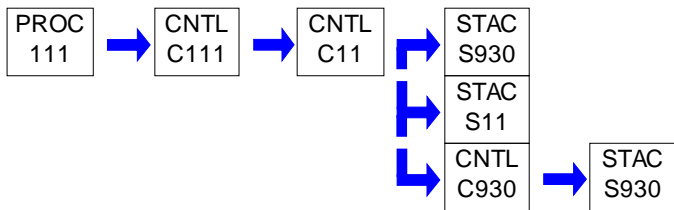
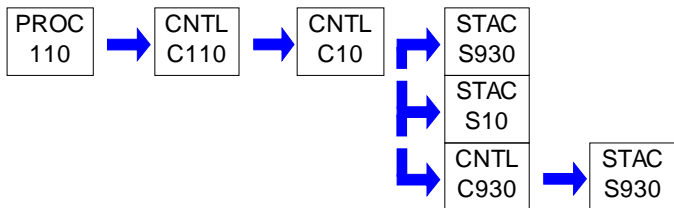



PERMIT MAPS



**SECTION B. General Title V Requirements****#001 [25 Pa. Code § 121.1]****Definitions**

Words and terms that are not otherwise defined in this permit shall have the meanings set forth in Section 3 of the Air Pollution Control Act (35 P.S. § 4003) and 25 Pa. Code § 121.1.

#002 [25 Pa. Code § 121.7]**Prohibition of Air Pollution**

No person may permit air pollution as that term is defined in the act.

#003 [25 Pa. Code § 127.512(c)(4)]**Property Rights**

This permit does not convey property rights of any sort, or any exclusive privileges.

#004 [25 Pa. Code § 127.446(a) and (c)]**Permit Expiration**

This operating permit is issued for a fixed term of five (5) years and shall expire on the date specified on Page 1 of this permit. The terms and conditions of the expired permit shall automatically continue pending issuance of a new Title V permit, provided the permittee has submitted a timely and complete application and paid applicable fees required under 25 Pa. Code Chapter 127, Subchapter I and the Department is unable, through no fault of the permittee, to issue or deny a new permit before the expiration of the previous permit. An application is complete if it contains sufficient information to begin processing the application, has the applicable sections completed and has been signed by a responsible official.

#005 [25 Pa. Code §§ 127.412, 127.413, 127.414, 127.446(e), 127.503 & 127.704(b)]**Permit Renewal**

(a) An application for the renewal of the Title V permit shall be submitted to the Department at least six (6) months, and not more than 18 months, before the expiration date of this permit. The renewal application is timely if a complete application is submitted to the Department's Regional Air Manager within the timeframe specified in this permit condition.

(b) The application for permit renewal shall include the current permit number, the appropriate permit renewal fee, a description of any permit revisions and off-permit changes that occurred during the permit term, and any applicable requirements that were promulgated and not incorporated into the permit during the permit term. The fees shall be made payable to "The Commonwealth of Pennsylvania Clean Air Fund" and submitted with the fee form to the respective regional office.

(c) The renewal application shall also include submission of proof that the local municipality and county, in which the facility is located, have been notified in accordance with 25 Pa. Code § 127.413. The application for renewal of the Title V permit shall also include submission of compliance review forms which have been used by the permittee to update information submitted in accordance with either 25 Pa. Code § 127.412(b) or § 127.412(j).

(d) The permittee, upon becoming aware that any relevant facts were omitted or incorrect information was submitted in the permit application, shall promptly submit such supplementary facts or corrected information during the permit renewal process. The permittee shall also promptly provide additional information as necessary to address any requirements that become applicable to the source after the date a complete renewal application was submitted but prior to release of a draft permit.

#006 [25 Pa. Code §§ 127.450(a)(4) & 127.464(a)]**Transfer of Ownership or Operational Control**

(a) In accordance with 25 Pa. Code § 127.450(a)(4), a change in ownership or operational control of the source shall be treated as an administrative amendment if:

- (1) The Department determines that no other change in the permit is necessary;
- (2) A written agreement has been submitted to the Department identifying the specific date of the transfer of permit responsibility, coverage and liability between the current and the new permittee; and,
- (3) A compliance review form has been submitted to the Department and the permit transfer has been approved by

**SECTION B. General Title V Requirements**

the Department.

(b) In accordance with 25 Pa. Code § 127.464(a), this permit may not be transferred to another person except in cases of transfer-of-ownership which are documented and approved to the satisfaction of the Department.

#007 [25 Pa. Code § 127.513, 35 P.S. § 4008 and § 114 of the CAA]**Inspection and Entry**

(a) Upon presentation of credentials and other documents as may be required by law for inspection and entry purposes, the permittee shall allow the Department of Environmental Protection or authorized representatives of the Department to perform the following:

- (1) Enter at reasonable times upon the permittee's premises where a Title V source is located or emissions related activity is conducted, or where records are kept under the conditions of this permit;
- (2) Have access to and copy or remove, at reasonable times, records that are kept under the conditions of this permit;
- (3) Inspect at reasonable times, facilities, equipment including monitoring and air pollution control equipment, practices, or operations regulated or required under this permit;
- (4) Sample or monitor, at reasonable times, substances or parameters, for the purpose of assuring compliance with the permit or applicable requirements as authorized by the Clean Air Act, the Air Pollution Control Act, or the regulations promulgated under the Acts.

(b) Pursuant to 35 P.S. § 4008, no person shall hinder, obstruct, prevent or interfere with the Department or its personnel in the performance of any duty authorized under the Air Pollution Control Act.

(c) Nothing in this permit condition shall limit the ability of the EPA to inspect or enter the premises of the permittee in accordance with Section 114 or other applicable provisions of the Clean Air Act.

#008 [25 Pa. Code §§ 127.25, 127.444, & 127.512(c)(1)]**Compliance Requirements**

(a) The permittee shall comply with the conditions of this permit. Noncompliance with this permit constitutes a violation of the Clean Air Act and the Air Pollution Control Act and is grounds for one (1) or more of the following:

- (1) Enforcement action
- (2) Permit termination, revocation and reissuance or modification
- (3) Denial of a permit renewal application

(b) A person may not cause or permit the operation of a source, which is subject to 25 Pa. Code Article III, unless the source(s) and air cleaning devices identified in the application for the plan approval and operating permit and the plan approval issued to the source are operated and maintained in accordance with specifications in the applications and the conditions in the plan approval and operating permit issued by the Department. A person may not cause or permit the operation of an air contamination source subject to 25 Pa. Code Chapter 127 in a manner inconsistent with good operating practices.

(c) For purposes of Sub-condition (b) of this permit condition, the specifications in applications for plan approvals and operating permits are the physical configurations and engineering design details which the Department determines are essential for the permittee's compliance with the applicable requirements in this Title V permit.

#009 [25 Pa. Code § 127.512(c)(2)]**Need to Halt or Reduce Activity Not a Defense**

It shall not be a defense for a permittee in an enforcement action that it would have been necessary to halt or reduce the permitted activity in order to maintain compliance with the conditions of this permit.

**SECTION B. General Title V Requirements****#010 [25 Pa. Code §§ 127.411(d) & 127.512(c)(5)]****Duty to Provide Information**

(a) The permittee shall furnish to the Department, within a reasonable time, information that the Department may request in writing to determine whether cause exists for modifying, revoking and reissuing, or terminating the permit, or to determine compliance with the permit.

(b) Upon request, the permittee shall also furnish to the Department copies of records that the permittee is required to keep by this permit, or for information claimed to be confidential, the permittee may furnish such records directly to the Administrator of EPA along with a claim of confidentiality.

#011 [25 Pa. Code §§ 127.463, 127.512(c)(3) & 127.542]**Reopening and Revising the Title V Permit for Cause**

(a) This Title V permit may be modified, revoked, reopened and reissued or terminated for cause. The filing of a request by the permittee for a permit modification, revocation and reissuance, or termination, or of a notification of planned changes or anticipated noncompliance does not stay a permit condition.

(b) This permit may be reopened, revised and reissued prior to expiration of the permit under one or more of the following circumstances:

(1) Additional applicable requirements under the Clean Air Act or the Air Pollution Control Act become applicable to a Title V facility with a remaining permit term of three (3) or more years prior to the expiration date of this permit. The Department will revise the permit as expeditiously as practicable but not later than 18 months after promulgation of the applicable standards or regulations. No such revision is required if the effective date of the requirement is later than the expiration date of this permit, unless the original permit or its terms and conditions has been extended.

(2) Additional requirements, including excess emissions requirements, become applicable to an affected source under the acid rain program. Upon approval by the Administrator of EPA, excess emissions offset plans for an affected source shall be incorporated into the permit.

(3) The Department or the EPA determines that this permit contains a material mistake or inaccurate statements were made in establishing the emissions standards or other terms or conditions of this permit.

(4) The Department or the Administrator of EPA determines that the permit must be revised or revoked to assure compliance with the applicable requirements.

(c) Proceedings to revise this permit shall follow the same procedures which apply to initial permit issuance and shall affect only those parts of this permit for which cause to revise exists. The revision shall be made as expeditiously as practicable.

(d) Regardless of whether a revision is made in accordance with (b)(1) above, the permittee shall meet the applicable standards or regulations promulgated under the Clean Air Act within the time frame required by standards or regulations.

#012 [25 Pa. Code § 127.543]**Reopening a Title V Permit for Cause by EPA**

As required by the Clean Air Act and regulations adopted thereunder, this permit may be modified, reopened and reissued, revoked or terminated for cause by EPA in accordance with procedures specified in 25 Pa. Code § 127.543.

#013 [25 Pa. Code § 127.522(a)]**Operating Permit Application Review by the EPA**

The applicant may be required by the Department to provide a copy of the permit application, including the compliance plan, directly to the Administrator of the EPA. Copies of title V permit applications to EPA, pursuant to 25 PA Code §127.522(a), shall be submitted, if required, to the following EPA e-mail box:

R3_Air_Apps_and_Notices@epa.gov

Please place the following in the subject line: TV [permit number], [Facility Name].

**SECTION B. General Title V Requirements****#014 [25 Pa. Code § 127.541]****Significant Operating Permit Modifications**

When permit modifications during the term of this permit do not qualify as minor permit modifications or administrative amendments, the permittee shall submit an application for significant Title V permit modifications in accordance with 25 Pa. Code § 127.541. Notifications to EPA, pursuant to 25 PA Code §127.522(a), if required, shall be submitted, to the following EPA e-mail box:

R3_Air_Apps_and_Notices@epa.gov

Please place the following in the subject line: TV [permit number], [Facility Name].

#015 [25 Pa. Code §§ 121.1 & 127.462]**Minor Operating Permit Modifications**

The permittee may make minor operating permit modifications (as defined in 25 Pa. Code §121.1), on an expedited basis, in accordance with 25 Pa. Code §127.462 (relating to minor operating permit modifications). Notifications to EPA, pursuant to 25 PA Code §127.462(c), if required, shall be submitted, to the following EPA e-mail box:

R3_Air_Apps_and_Notices@epa.gov

Please place the following in the subject line: TV [permit number], [Facility Name].

#016 [25 Pa. Code § 127.450]**Administrative Operating Permit Amendments**

(a) The permittee may request administrative operating permit amendments, as defined in 25 Pa. Code §127.450(a). Copies of request for administrative permit amendment to EPA, pursuant to 25 PA Code §127.450(c)(1), if required, shall be submitted to the following EPA e-mail box:

R3_Air_Apps_and_Notices@epa.gov

Please place the following in the subject line: TV [permit number], [Facility Name].

(b) Upon final action by the Department granting a request for an administrative operating permit amendment covered under §127.450(a)(5), the permit shield provisions in 25 Pa. Code § 127.516 (relating to permit shield) shall apply to administrative permit amendments incorporated in this Title V Permit in accordance with §127.450(c), unless precluded by the Clean Air Act or the regulations thereunder.

#017 [25 Pa. Code § 127.512(b)]**Severability Clause**

The provisions of this permit are severable, and if any provision of this permit is determined by the Environmental Hearing Board or a court of competent jurisdiction, or US EPA to be invalid or unenforceable, such a determination will not affect the remaining provisions of this permit.

#018 [25 Pa. Code §§ 127.704, 127.705 & 127.707]**Fee Payment**

(a) The permittee shall pay fees to the Department in accordance with the applicable fee schedules in 25 Pa. Code Chapter 127, Subchapter I (relating to plan approval and operating permit fees). The applicable fees shall be made payable to "The Commonwealth of Pennsylvania Clean Air Fund" with the permit number clearly indicated and submitted to the respective regional office.

(b) Emission Fees. The permittee shall, on or before September 1st of each year, pay applicable annual Title V emission fees for emissions occurring in the previous calendar year as specified in 25 Pa. Code § 127.705. The permittee is not required to pay an emission fee for emissions of more than 4,000 tons of each regulated pollutant emitted from the facility.

(c) As used in this permit condition, the term "regulated pollutant" is defined as a VOC, each pollutant regulated under Sections 111 and 112 of the Clean Air Act and each pollutant for which a National Ambient Air Quality Standard has been promulgated, except that carbon monoxide is excluded.

**SECTION B. General Title V Requirements**

(d) Late Payment. Late payment of emission fees will subject the permittee to the penalties prescribed in 25 Pa. Code § 127.707 and may result in the suspension or termination of the Title V permit. The permittee shall pay a penalty of fifty percent (50%) of the fee amount, plus interest on the fee amount computed in accordance with 26 U.S.C.A. § 6621(a)(2) from the date the emission fee should have been paid in accordance with the time frame specified in 25 Pa. Code § 127.705(c).

(e) The permittee shall pay an annual operating permit maintenance fee according to the following fee schedule established in 25 Pa. Code § 127.704(d) on or before December 31 of each year for the next calendar year.

(1) Eight thousand dollars (\$8,000) for calendar years 2021—2025.

(2) Ten thousand dollars (\$10,000) for calendar years 2026—2030.

(3) Twelve thousand five hundred dollars (\$12,500) for the calendar years beginning with 2031.

#019 [25 Pa. Code §§ 127.14(b) & 127.449]**Authorization for De Minimis Emission Increases**

(a) This permit authorizes de minimis emission increases from a new or existing source in accordance with 25 Pa. Code §§ 127.14 and 127.449 without the need for a plan approval or prior issuance of a permit modification. The permittee shall provide the Department with seven (7) days prior written notice before commencing any de minimis emissions increase that would result from either: (1) a physical change of minor significance under § 127.14(c)(1); or (2) the construction, installation, modification or reactivation of an air contamination source. The written notice shall:

(1) Identify and describe the pollutants that will be emitted as a result of the de minimis emissions increase.

(2) Provide emission rates expressed in tons per year and in terms necessary to establish compliance consistent with any applicable requirement.

The Department may disapprove or condition de minimis emission increases at any time.

(b) Except as provided below in (c) and (d) of this permit condition, the permittee is authorized during the term of this permit to make de minimis emission increases (expressed in tons per year) up to the following amounts without the need for a plan approval or prior issuance of a permit modification:

(1) Four tons of carbon monoxide from a single source during the term of the permit and 20 tons of carbon monoxide at the facility during the term of the permit.

(2) One ton of NO_x from a single source during the term of the permit and 5 tons of NO_x at the facility during the term of the permit.

(3) One and six-tenths tons of the oxides of sulfur from a single source during the term of the permit and 8.0 tons of oxides of sulfur at the facility during the term of the permit.

(4) Six-tenths of a ton of PM₁₀ from a single source during the term of the permit and 3.0 tons of PM₁₀ at the facility during the term of the permit. This shall include emissions of a pollutant regulated under Section 112 of the Clean Air Act unless precluded by the Clean Air Act or 25 Pa. Code Article III.

(5) One ton of VOCs from a single source during the term of the permit and 5.0 tons of VOCs at the facility during the term of the permit. This shall include emissions of a pollutant regulated under Section 112 of the Clean Air Act unless precluded by the Clean Air Act or 25 Pa. Code Article III.

(c) In accordance with § 127.14, the permittee may install the following minor sources without the need for a plan approval:

(1) Air conditioning or ventilation systems not designed to remove pollutants generated or released from other sources.

(2) Combustion units rated at 2,500,000 or less Btu per hour of heat input.

**SECTION B. General Title V Requirements**

(3) Combustion units with a rated capacity of less than 10,000,000 Btu per hour heat input fueled by natural gas supplied by a public utility, liquefied petroleum gas or by commercial fuel oils which are No. 2 or lighter, viscosity less than or equal to 5.82 c St, and which meet the sulfur content requirements of 25 Pa. Code § 123.22 (relating to combustion units). For purposes of this permit, commercial fuel oil shall be virgin oil which has no reprocessed, recycled or waste material added.

(4) Space heaters which heat by direct heat transfer.

(5) Laboratory equipment used exclusively for chemical or physical analysis.

(6) Other sources and classes of sources determined to be of minor significance by the Department.

(d) This permit does not authorize de minimis emission increases if the emissions increase would cause one or more of the following:

(1) Increase the emissions of a pollutant regulated under Section 112 of the Clean Air Act except as authorized in Subparagraphs (b)(4) and (5) of this permit condition.

(2) Subject the facility to the prevention of significant deterioration requirements in 25 Pa. Code Chapter 127, Subchapter D and/or the new source review requirements in Subchapter E.

(3) Violate any applicable requirement of the Air Pollution Control Act, the Clean Air Act, or the regulations promulgated under either of the acts.

(4) Changes which are modifications under any provision of Title I of the Clean Air Act and emission increases which would exceed the allowable emissions level (expressed as a rate of emissions or in terms of total emissions) under the Title V permit.

(e) Unless precluded by the Clean Air Act or the regulations thereunder, the permit shield described in 25 Pa. Code § 127.516 (relating to permit shield) shall extend to the changes made under 25 Pa. Code § 127.449 (relating to de minimis emission increases).

(f) Emissions authorized under this permit condition shall be included in the monitoring, recordkeeping and reporting requirements of this permit.

(g) Except for de minimis emission increases allowed under this permit, 25 Pa. Code § 127.449, or sources and physical changes meeting the requirements of 25 Pa. Code § 127.14, the permittee is prohibited from making physical changes or engaging in activities that are not specifically authorized under this permit without first applying for a plan approval. In accordance with § 127.14(b), a plan approval is not required for the construction, modification, reactivation, or installation of the sources creating the de minimis emissions increase.

(h) The permittee may not meet de minimis emission threshold levels by offsetting emission increases or decreases at the same source.

#020 [25 Pa. Code §§ 127.11a & 127.215]**Reactivation of Sources**

(a) The permittee may reactivate a source at the facility that has been out of operation or production for at least one year, but less than or equal to five (5) years, if the source is reactivated in accordance with the requirements of 25 Pa. Code §§ 127.11a and 127.215. The reactivated source will not be considered a new source.

(b) A source which has been out of operation or production for more than five (5) years but less than 10 years may be reactivated and will not be considered a new source if the permittee satisfies the conditions specified in 25 Pa. Code § 127.11a(b).

#021 [25 Pa. Code §§ 121.9 & 127.216]**Circumvention**

(a) The owner of this Title V facility, or any other person, may not circumvent the new source review requirements of 25 Pa. Code Chapter 127, Subchapter E by causing or allowing a pattern of ownership or development, including the

**SECTION B. General Title V Requirements**

phasing, staging, delaying or engaging in incremental construction, over a geographic area of a facility which, except for the pattern of ownership or development, would otherwise require a permit or submission of a plan approval application.

(b) No person may permit the use of a device, stack height which exceeds good engineering practice stack height, dispersion technique or other technique which, without resulting in reduction of the total amount of air contaminants emitted, conceals or dilutes an emission of air contaminants which would otherwise be in violation of this permit, the Air Pollution Control Act or the regulations promulgated thereunder, except that with prior approval of the Department, the device or technique may be used for control of malodors.

#022 [25 Pa. Code §§ 127.402(d) & 127.513(1)]**Submissions**

(a) Reports, test data, monitoring data, notifications and requests for renewal of the permit shall be submitted to the:

Regional Air Program Manager
PA Department of Environmental Protection
(At the address given on the permit transmittal letter, or otherwise notified)

(b) Any report or notification for the EPA Administrator or EPA Region III should be addressed to:

Enforcement & Compliance Assurance Division
Air, RCRA and Toxics Branch
Air Section
1650 Arch Street, 3ED21
Philadelphia, PA 19103

The Title V compliance certification shall be emailed to EPA at R3_APD_Permits@epa.gov.

(c) An application, form, report or compliance certification submitted pursuant to this permit condition shall contain certification by a responsible official as to truth, accuracy, and completeness as required under 25 Pa. Code § 127.402(d). Unless otherwise required by the Clean Air Act or regulations adopted thereunder, this certification and any other certification required pursuant to this permit shall state that, based on information and belief formed after reasonable inquiry, the statements and information in the document are true, accurate and complete.

#023 [25 Pa. Code §§ 127.441(c) & 127.463(e); Chapter 139; & 114(a)(3), 504(b) of the CAA]**Sampling, Testing and Monitoring Procedures**

(a) The permittee shall perform the emissions monitoring and analysis procedures or test methods for applicable requirements of this Title V permit. In addition to the sampling, testing and monitoring procedures specified in this permit, the Permittee shall comply with any additional applicable requirements promulgated under the Clean Air Act after permit issuance regardless of whether the permit is revised.

(b) The sampling, testing and monitoring required under the applicable requirements of this permit, shall be conducted in accordance with the requirements of 25 Pa. Code Chapter 139 unless alternative methodology is required by the Clean Air Act (including §§ 114(a)(3) and 504(b)) and regulations adopted thereunder.

#024 [25 Pa. Code §§ 127.511 & Chapter 135]**Recordkeeping Requirements**

(a) The permittee shall maintain and make available, upon request by the Department, records of required monitoring information that include the following:

- (1) The date, place (as defined in the permit) and time of sampling or measurements.
- (2) The dates the analyses were performed.
- (3) The company or entity that performed the analyses.
- (4) The analytical techniques or methods used.

**SECTION B. General Title V Requirements**

(5) The results of the analyses.

(6) The operating conditions as existing at the time of sampling or measurement.

(b) The permittee shall retain records of the required monitoring data and supporting information for at least five (5) years from the date of the monitoring sample, measurement, report or application. Supporting information includes the calibration data and maintenance records and original strip-chart recordings for continuous monitoring instrumentation, and copies of reports required by the permit.

(c) The permittee shall maintain and make available to the Department upon request, records including computerized records that may be necessary to comply with the reporting, recordkeeping and emission statement requirements in 25 Pa. Code Chapter 135 (relating to reporting of sources). In accordance with 25 Pa. Code Chapter 135, § 135.5, such records may include records of production, fuel usage, maintenance of production or pollution control equipment or other information determined by the Department to be necessary for identification and quantification of potential and actual air contaminant emissions. If direct recordkeeping is not possible or practical, sufficient records shall be kept to provide the needed information by indirect means.

#025 [25 Pa. Code §§ 127.411(d), 127.442, 127.463(e) & 127.511(c)]**Reporting Requirements**

(a) The permittee shall comply with the reporting requirements for the applicable requirements specified in this Title V permit. In addition to the reporting requirements specified herein, the permittee shall comply with any additional applicable reporting requirements promulgated under the Clean Air Act after permit issuance regardless of whether the permit is revised.

(b) Pursuant to 25 Pa. Code § 127.511(c), the permittee shall submit reports of required monitoring at least every six (6) months unless otherwise specified in this permit. Instances of deviations (as defined in 25 Pa. Code § 121.1) from permit requirements shall be clearly identified in the reports. The reporting of deviations shall include the probable cause of the deviations and corrective actions or preventative measures taken, except that sources with continuous emission monitoring systems shall report according to the protocol established and approved by the Department for the source. The required reports shall be certified by a responsible official.

(c) Every report submitted to the Department under this permit condition shall comply with the submission procedures specified in Section B, Condition #022(c) of this permit.

(d) Any records, reports or information obtained by the Department or referred to in a public hearing shall be made available to the public by the Department except for such records, reports or information for which the permittee has shown cause that the documents should be considered confidential and protected from disclosure to the public under Section 4013.2 of the Air Pollution Control Act and consistent with Sections 112(d) and 114(c) of the Clean Air Act and 25 Pa. Code § 127.411(d). The permittee may not request a claim of confidentiality for any emissions data generated for the Title V facility.

#026 [25 Pa. Code § 127.513]**Compliance Certification**

(a) One year after the date of issuance of the Title V permit, and each year thereafter, unless specified elsewhere in the permit, the permittee shall submit to the Department and EPA Region III a certificate of compliance with the terms and conditions in this permit, for the previous year, including the emission limitations, standards or work practices. This certification shall include:

- (1) The identification of each term or condition of the permit that is the basis of the certification.
- (2) The compliance status.
- (3) The methods used for determining the compliance status of the source, currently and over the reporting period.
- (4) Whether compliance was continuous or intermittent.

(b) The compliance certification shall be postmarked or hand-delivered no later than thirty days after each anniversary of the date of issuance of this Title V Operating Permit, or on the submittal date specified elsewhere in the permit, to the Department in accordance with the submission requirements specified in Section B, Condition #022 of this permit. The Title V compliance certification shall be emailed to EPA at R3_APD_Permits@epa.gov.

**SECTION B. General Title V Requirements****#027 [25 Pa. Code § 127.3]****Operational Flexibility**

The permittee is authorized to make changes within the Title V facility in accordance with the following provisions in 25 Pa. Code Chapter 127 which implement the operational flexibility requirements of Section 502(b)(10) of the Clean Air Act and Section 6.1(i) of the Air Pollution Control Act:

- (1) Section 127.14 (relating to exemptions)
- (2) Section 127.447 (relating to alternative operating scenarios)
- (3) Section 127.448 (relating to emissions trading at facilities with federally enforceable emissions caps)
- (4) Section 127.449 (relating to de minimis emission increases)
- (5) Section 127.450 (relating to administrative operating permit amendments)
- (6) Section 127.462 (relating to minor operating permit amendments)
- (7) Subchapter H (relating to general plan approvals and operating permits)

#028 [25 Pa. Code §§ 127.441(d), 127.512(i) and 40 CFR Part 68]**Risk Management**

(a) If required by Section 112(r) of the Clean Air Act, the permittee shall develop and implement an accidental release program consistent with requirements of the Clean Air Act, 40 CFR Part 68 (relating to chemical accident prevention provisions) and the Federal Chemical Safety Information, Site Security and Fuels Regulatory Relief Act (P.L. 106-40).

(b) The permittee shall prepare and implement a Risk Management Plan (RMP) which meets the requirements of Section 112(r) of the Clean Air Act, 40 CFR Part 68 and the Federal Chemical Safety Information, Site Security and Fuels Regulatory Relief Act when a regulated substance listed in 40 CFR § 68.130 is present in a process in more than the listed threshold quantity at the Title V facility. The permittee shall submit the RMP to the federal Environmental Protection Agency according to the following schedule and requirements:

- (1) The permittee shall submit the first RMP to a central point specified by EPA no later than the latest of the following:
 - (i) Three years after the date on which a regulated substance is first listed under § 68.130; or,
 - (ii) The date on which a regulated substance is first present above a threshold quantity in a process.

(2) The permittee shall submit any additional relevant information requested by the Department or EPA concerning the RMP and shall make subsequent submissions of RMPs in accordance with 40 CFR § 68.190.

(3) The permittee shall certify that the RMP is accurate and complete in accordance with the requirements of 40 CFR Part 68, including a checklist addressing the required elements of a complete RMP.

(c) As used in this permit condition, the term "process" shall be as defined in 40 CFR § 68.3. The term "process" means any activity involving a regulated substance including any use, storage, manufacturing, handling, or on-site movement of such substances or any combination of these activities. For purposes of this definition, any group of vessels that are interconnected, or separate vessels that are located such that a regulated substance could be involved in a potential release, shall be considered a single process.

(d) If the Title V facility is subject to 40 CFR Part 68, as part of the certification required under this permit, the permittee shall:

- (1) Submit a compliance schedule for satisfying the requirements of 40 CFR Part 68 by the date specified in 40 CFR § 68.10(a); or,
- (2) Certify that the Title V facility is in compliance with all requirements of 40 CFR Part 68 including the registration and submission of the RMP.

**SECTION B. General Title V Requirements**

(e) If the Title V facility is subject to 40 CFR Part 68, the permittee shall maintain records supporting the implementation of an accidental release program for five (5) years in accordance with 40 CFR § 68.200.

(f) When the Title V facility is subject to the accidental release program requirements of Section 112(r) of the Clean Air Act and 40 CFR Part 68, appropriate enforcement action will be taken by the Department if:

(1) The permittee fails to register and submit the RMP or a revised plan pursuant to 40 CFR Part 68.

(2) The permittee fails to submit a compliance schedule or include a statement in the compliance certification required under Section B, Condition #026 of this permit that the Title V facility is in compliance with the requirements of Section 112(r) of the Clean Air Act, 40 CFR Part 68, and 25 Pa. Code § 127.512(i).

#029 [25 Pa. Code § 127.512(e)]**Approved Economic Incentives and Emission Trading Programs**

No permit revision shall be required under approved economic incentives, marketable permits, emissions trading and other similar programs or processes for changes that are provided for in this Title V permit.

#030 [25 Pa. Code §§ 127.516, 127.450(d), 127.449(f) & 127.462(g)]**Permit Shield**

(a) The permittee's compliance with the conditions of this permit shall be deemed in compliance with applicable requirements (as defined in 25 Pa. Code § 121.1) as of the date of permit issuance if either of the following applies:

(1) The applicable requirements are included and are specifically identified in this permit.

(2) The Department specifically identifies in the permit other requirements that are not applicable to the permitted facility or source.

(b) Nothing in 25 Pa. Code § 127.516 or the Title V permit shall alter or affect the following:

(1) The provisions of Section 303 of the Clean Air Act, including the authority of the Administrator of the EPA provided thereunder.

(2) The liability of the permittee for a violation of an applicable requirement prior to the time of permit issuance.

(3) The applicable requirements of the acid rain program, consistent with Section 408(a) of the Clean Air Act.

(4) The ability of the EPA to obtain information from the permittee under Section 114 of the Clean Air Act.

(c) Unless precluded by the Clean Air Act or regulations thereunder, final action by the Department incorporating a significant permit modification in this Title V Permit shall be covered by the permit shield at the time that the permit containing the significant modification is issued.

#031 [25 Pa. Code §135.3]**Reporting**

(a) The permittee shall submit by March 1 of each year an annual emissions report for the preceding calendar year. The report shall include information for all active previously reported sources, new sources which were first operated during the preceding calendar year, and sources modified during the same period which were not previously reported. All air emissions from the facility should be estimated and reported.

(b) A source owner or operator may request an extension of time from the Department for the filing of an annual emissions report, and the Department may grant the extension for reasonable cause.

#032 [25 Pa. Code §135.4]**Report Format**

Emissions reports shall contain sufficient information to enable the Department to complete its emission inventory. Emissions reports shall be made by the source owner or operator in a format specified by the Department.

**SECTION C. Site Level Requirements****I. RESTRICTIONS.****Emission Restriction(s).****# 001 [25 Pa. Code §121.7]****Prohibition of air pollution.**

No person may permit air pollution as that term is defined in the Act.

002 [25 Pa. Code §123.1]**Prohibition of certain fugitive emissions**

No person may permit the emission into the outdoor atmosphere of fugitive air contaminant from a source other than the following:

- (a) construction or demolition of buildings or structures;
- (b) grading, paving and maintenance of roads and streets;
- (c) use of roads and streets. Emissions from material in or on trucks, railroad cars and other vehicular equipment are not considered as emissions from use of roads and streets;
- (d) clearing of land;
- (e) stockpiling of materials;
- (f) open burning operations, as specified in 25 Pa. Code § 129.14;
- (g) blasting in open pit mines. Emissions from drilling are not considered as emissions from blasting;
- (h) coke oven batteries, provided the fugitive air contaminants emitted from any coke oven battery comply with the standards for visible fugitive emissions in 25 Pa. Code §§ 123.44 and 129.15 (relating to limitations of visible fugitive air contaminants from operation of any coke oven battery; and coke pushing operations); and
- (i) sources and classes of sources other than those identified in (a)-(h), above, for which the permittee has obtained a determination from the Department that fugitive emissions from the source, after appropriate control, meet the following requirements:
 - (1) the emissions are of minor significance with respect to causing air pollution; and
 - (2) the emissions are not preventing or interfering with the attainment or maintenance of any ambient air quality standard.

003 [25 Pa. Code §123.2]**Fugitive particulate matter**

A person may not permit fugitive particulate matter to be emitted into the outdoor atmosphere from a source specified in 25 Pa. Code § 123.1(a)(1)-(9) (relating to prohibition of certain fugitive emissions) if such emissions are visible at the point the emissions pass outside the person's property.

004 [25 Pa. Code §123.31]**Limitations**

A person may not permit the emission into the outdoor atmosphere of any malodorous air contaminants from any source in such a manner that the malodors are detectable outside the property of the person on whose land the source is being operated.

005 [25 Pa. Code §123.41]**Limitations**

A person may not permit the emission into the outdoor atmosphere of visible air contaminants in such a manner that the opacity of the emission is either of the following:

- (a). Equal to or greater than 20% for a period or periods aggregating more than three minutes in any one (1) hour.
- (b). Equal to or greater than 60% at any time.

006 [25 Pa. Code §123.42]**Exceptions**

The opacity limitations as per 25 Pa. Code § 123.41 shall not apply to a visible emission in either of the following instances:

**SECTION C. Site Level Requirements**

- (a) When the presence of uncombined water is the only reason for failure to meet the limitations.
- (b) When the emission results from the operation of equipment used solely to train and test persons in observing the opacity of visible emissions.
- (c) When the emission results from the sources specified in 25 Pa. Code § 123.1(a)(1)-(9) (relating to prohibition of certain fugitive emissions).

007 [25 Pa. Code §127.441]**Operating permit terms and conditions.**

[Additional authority for this permit condition is also derived from 25 Pa. Code §§ 127.511, 127.512(h) and §§ 129.91 - 129.95.]

The NO_x (Nitrogen Oxides) emissions for this facility shall be less than 25 tons per year on a 12 month rolling basis.

008 [25 Pa. Code §127.441]**Operating permit terms and conditions.**

(a). The facility wide toluene emissions or any single hazardous air pollutant (HAP) emissions shall not exceed 9.99 tons per year in a 12-month rolling sum.

(b). The combined HAP emissions from the facility shall not exceed 24.99 tons per year in a 12-month rolling sum.

(c). The volatile organic compound (VOC) emissions from this facility shall not exceed 49.9 tons per year on a 12-month rolling period.

(d). The finished product from this facility shall not exceed 50,000,000 pounds per year on a 12-month rolling period.

(e) Exceedences of sub-condition (c) of this permit condition will result in the facility being subjected to 25 Pa. Code §§129.96-129.100.

009 [25 Pa. Code §129.14]**Open burning operations**

The permittee may not permit the open burning of material in the Southeast Air Basin, except when the open burning results from:

- (a) A fire set to prevent or abate a fire hazard, when approved by the Department and set by or under the supervision of a public officer.
- (b) Any fire set for the purpose of instructing personnel in fire fighting, when approved by the Department.
- (c) A fire set for the prevention and control of disease or pests, when approved by the Department.
- (d) A fire set in conjunction with the production of agricultural commodities in their unmanufactured state on the premises of the farm operation.
- (e) A fire set for the purpose of burning domestic refuse, when the fire is on the premises of a structure occupied solely as a dwelling by two families or less and when the refuse results from the normal occupancy of the structure.
- (f) A fire set solely for recreational or ceremonial purposes.
- (g) A fire set solely for cooking food.

II. TESTING REQUIREMENTS.**# 010 [25 Pa. Code §127.441]****Operating permit terms and conditions.**

[Additional authority for this permit condition is also derived from 25 Pa. Code § 127.512.]

- (a) If at any time the Department has cause to believe that air contaminant emissions from any source(s) listed in Section A, of this Permit, may be in excess of the limitations specified in this Permit, or established pursuant to, any applicable rule or regulation contained in 25 Pa. Code Article III, the permittee shall be required to conduct whatever tests are deemed necessary by the Department to determine the actual emission rate(s).

**SECTION C. Site Level Requirements**

(b) Such testing shall be conducted in accordance with the provisions of 25 Pa. Code Chapter 139 and the most current version of the DEP Source Testing Manual, when applicable, and in accordance with any restrictions or limitations established by the Department at such time as it notifies the permittee that testing is required.

011 [25 Pa. Code §127.441]**Operating permit terms and conditions.**

(a). The permittee shall test the series of condensers for emissions testing to determine the emissions of heptane and toluene. Testing will include the following sources: Sources 110,111,112,115 and 117 using one of the following:

(1). Overall Efficiency Testing - tests performed, using a Department approved method, to determine both the inlet vapor composition into the primary condenser in pounds per hour and the outlet vapor composition of the final condenser in pounds per hour.

(2). Emissions Determination - the inlet vapor composition to the primary condenser in pounds per hour is determined by Department approved equations and/or data, and the outlet vapor composition of the final condenser in pounds per hour is determined by Department approved stack testing performed in accordance with 25 Pa. Code Chapter 139. The Department reserves the right to require overall efficiency testing if it is determined that the equations and/or data proposed for use in this method do not provide reasonable data on the composition of the inlet to the primary condenser.

(b). The permittee shall perform one of the stack tests listed in (a) above for the series of condensers, using the Department approved procedures for stack testing.

(c) The permittee shall perform a stack test using the Department-approved procedures once every five (5) calendar years, where five calendar years is defined as beginning with the calendar year the latest stack test was performed and ending on December 31, five years later. Performance tests shall be conducted while the source is operating at maximum routine operating conditions or under such other conditions, within the capacity of the equipment, as may be requested by the Department. When testing of a source is required on a recurring basis, a single procedural protocol may be submitted for approval; thereafter, a letter referencing the previously approved procedural protocol is sufficient. However, if modifications are made to the process(es), if a different stack testing company is used, or if an applicable section of the stack testing manual has been revised since approval, a new protocol must be submitted for approval.

(d). At least ninety (90) days prior to the test, the company shall submit to the Department for approval the procedures for the test and a sketch with dimensions indicating the location of sampling ports and other data to ensure the collection of representative samples. The testing protocol shall include which method in paragraph (a) of this condition will be used to determine overall efficiency.

(e). At least thirty (30) days prior to the test, the Regional Air Quality Manager shall be informed of the date and time of the test.

(f). Within sixty (60) days after the source test(s) (unless a more stringent regulatory requirement applies), one paper copy plus one electronic copy of the complete test report, including all operating conditions, shall be submitted to the Regional Air Quality Manager for approval.

(g) In the event that any of the above deadlines cannot be met, the permittee may request an extension for the due date(s) in writing and include a justification for the extension. The Department may grant an extension for a reasonable cause.

012 [25 Pa. Code §127.441]**Operating permit terms and conditions.**

(a) The permittee shall submit one paper copy plus one electronic copy of all source test submissions (notifications, protocols, reports, supplemental information, etc.) to both the AQ Program Manager for the Southeast Regional Office and the PSIMS Administrator in Central Office (mail and email addresses are provided below). Any questions or concerns about source testing submissions can be sent to RA-EPstacktesting@pa.gov and the PSIMS Administrator will address them.

(b) The following pertinent information shall be listed on the title page.

1. Test Date(s)

**SECTION C. Site Level Requirements**

- a. For protocols, provide the proposed date on which testing will commence or "TBD"
 - b. For reports, provide the first and last day of testing
2. Facility Identification Number (Facility - ID): For test programs that were conducted under a multi-site protocol, also include the PF Id under which the protocol was stored in PSIMS, as indicated in the protocol response letter.
3. Source ID(s) for the applicable source(s) and air pollution control device(s): The term Source ID is used in the permit but "Other Id" is used in DEP electronic systems. They are the same number and must also be listed for control equipment
4. Testing Requirements (all that apply)
- a. Plan approval number(s)
 - b. Operating permit number
 - c. Applicable federal subpart(s) (i.e. 40 CFR 60, Subpart JJJJ)
 - d. Special purpose(s) (Consent Order, RFD, RACT II, Tier II, etc.)
- (c) Mail all paper submissions to both the PSIMS Administrator and the Air Quality Program Manager for the Southeast Regional Office. Mailing addresses are provided below.
- Central Office
Pennsylvania Department of Environmental Protection
Attn: PSIMS Administrator
P.O. Box 8468
Harrisburg, PA 17105-8468
- Southeast Region
Pennsylvania Department of Environmental Protection
Attn: Air Quality Program Manager
2 East Main Street
Norristown, PA 19401
- (d) Eliminate shading, color ink for data emphasis, small font size, and color saturation as the scanning to create an electronic file is done in black and white. Shading and color emphasis do not scan well and make the electronic copies difficult to read.
- (e) Email all electronic submissions to both the PSIMS Administrator in Central Office and the Air Quality Program Manager for the Southeast Regional Office. Email addresses are provided below.
- Central Office
RA-EPstacktesting@pa.gov
- Southeast Region
RA-EPSEstacktesting@pa.gov
- (f) The Department limits emails to 15 MB and PSIMS has a file size limitation of 100 MB for electronic files. Submit just one electronic file (convert any Microsoft Word or Excel files to an Adobe PDF format and combine them with the report or protocol), unless the submission contains CONFIDENTIAL information.
- (g) If confidential information must be submitted, submit both a public copy, which has been redacted, and a confidential copy. The cover page of each submittal should state whether it is a "Public Copy" or "Confidential Copy" and each page of the latter must be marked "CONFIDENTIAL".

**SECTION C. Site Level Requirements****III. MONITORING REQUIREMENTS.****# 013 [25 Pa. Code §123.43]****Measuring techniques**

Visible emissions, pursuant to Condition #005 of this section may be measured using either of the following:

- (a) A device approved by the Department and maintained to provide accurate opacity measurements.
- (b) Observers, trained and qualified to measure plume opacity with the naked eye or with the aid of any devices approved by the Department.

014 [25 Pa. Code §127.441]**Operating permit terms and conditions.**

[Additional authority for this permit condition is also derived from 25 Pa. Code §§ 127.511, 127.512(h) and §§ 129.91 - 129.95.]

The permittee shall maintain NO_x and VOC emission tracking system to document compliance with the emissions limitations stated elsewhere in this permit and to document the emissions from the facility. The tracking system must be approved by the Department.

015 [25 Pa. Code §127.441]**Operating permit terms and conditions.**

[Additional authority for this permit condition is also derived from 25 Pa. Code § 127.511]

- (a). The permittee shall monitor the facility, once per operating day, for the following:
 - (1). Odors, which the Department may determine to be objectionable to the public.
 - (2). Visible Emissions.
 - (3). Fugitive Particulate Matter.
- (b). All detectable fugitive particulate emissions, and/or objectionable odors, that originated on-site and cross the property line as well as visible emissions that originate on site shall:
 - (1). Be investigated.
 - (2). Be reported to the facility management, or individual(s) designated by the permittee.
 - (3). Be recorded in media approved by the Department.
- (c). At the end of six months, upon the permittee's request, the Department will determine the feasibility of decreasing the monitoring frequency to weekly for the next six month period.
- (d). At the end of the second six month period, upon the permittee's request, the Department will determine the feasibility of decreasing the frequency of monitoring to monthly.
- (e). The Department reserves the right to change the above monitoring requirements at any time, based on but not limited to: the review of the compliance certification and the semi-annual report of monitoring and record keeping, complaints, monitoring results, and/or Department findings.

IV. RECORDKEEPING REQUIREMENTS.**# 016 [25 Pa. Code §127.441]****Operating permit terms and conditions.**

[Additional authority for this permit condition is also derived from 25 Pa. Code §§ 127.511, 127.512(h) and §§ 129.91 - 129.95.]

**SECTION C. Site Level Requirements**

- (a). The permittee shall keep records from the established NOx and VOC emission tracking system to document compliance with the emissions limitations stated elsewhere in this permit and to document the emissions from the facility. The tracking system must be approved by the Department.
- (b). The permittee shall maintain comprehensive records for
- (1). All de minimus sources in a Department approved format to demonstrate compliance with the de minimus limits.
 - (2). All fugitive sources checked manually at least every four (4) hours.
- (c). The permittee shall keep records to demonstrate compliance with all permit conditions contained in this permit.
- (d). To establish compliance, the permittee shall keep and make available to the Department personnel those specifications for maintenance and operations that have been supplied by the manufacturer for equipment listed in Sections A and D of this permit.

017 [25 Pa. Code §127.441]
Operating permit terms and conditions.

[Additional authority for this permit condition is also derived from 25 Pa. Code §§ 127.511, 127.512(h) and §§ 129.91 - 129.95.]

The permittee shall keep records to demonstrate compliance with all permit conditions contained in this permit.

018 [25 Pa. Code §127.441]
Operating permit terms and conditions.

[Additional authority for this permit condition is also derived from 25 Pa. Code § 127.511.]

- (a). Records of the monitoring data and supporting information required by this permit shall be maintained for a minimum of five (5) years.
- (b). The owner or operator shall calculate and record the total amount of finished product produced on a 12-month rolling sum basis.
- (c). The owner or operator shall calculate and record the total amount of volatile organic compound (VOC) emissions on a 12-month rolling sum basis.
- (d). Within 30 days of permit issuance the permittee shall submit, to the Department for approval, the revised formats that records required in Subparagraph (a) above are to be kept in.

019 [25 Pa. Code §127.441]
Operating permit terms and conditions.

[Additional authority for this permit condition is also derived from 25 Pa. Code § 127.511.]

The permittee shall record, at a minimum, the following information relating to reports of malodors, fugitive particulate emission not authorized by Condition #002 of this section and/or exceedances of the visible emissions standard from any sources listed in Section A of this permit:

- (a). Date, time, place of incident(s).
- (b). Results of the investigation.
- (c). Any corrective action taken.

**SECTION C. Site Level Requirements****# 020 [25 Pa. Code §127.441]****Operating permit terms and conditions.**

[Additional authority for this permit condition is also derived from 25 Pa. Code § 127.511.]

For each event when the facility is monitored for odors, visible emissions, or fugitive particulate matter, operations personnel shall keep a record of their observations and findings.

021 [25 Pa. Code §137.4]**Standby plans**

The company shall prepare and maintain a standby plan on the premises and it shall be available to the Department upon request or in the event of an air pollution episode.

V. REPORTING REQUIREMENTS.**# 022 [25 Pa. Code §127.441]****Operating permit terms and conditions.**

[Additional authority for this permit condition is also derived from 25 Pa. Code § 127.511.]

(a). The permittee shall report, at a minimum, the following information relating to the reports malodors, and/or exceedances of any visible emissions and/or fugitive particulate emissions:

- (1). Date, time, and location of the incident(s).
- (2). Results of the investigation.
- (3). Any corrective action taken.

(b). These records shall be in a format approved by the Department, and kept as a permanent record.

023 [25 Pa. Code §127.441]**Operating permit terms and conditions.**

[Additional authority for this permit condition is also derived from 25 Pa. Code § 127.511(c).]

The permittee shall submit the following reports:

(a) An annual certificate of compliance, due by April 1st of each year, for the period covering January 1 through December 31 of the previous year. This certificate of compliance shall document compliance with all permit terms and conditions set forth in this Title V permit as required under condition #24 of section B of this permit. . The annual certificate of compliance shall be submitted to the Department in paper form, and EPA Region III in electronic form at the following email address:

R3_APD_Permits@epa.gov

(b) A semi annual deviation report, due by October 1, of each year, for the period covering January 1 through June 30 of the same year. Note: The annual certification of compliance fulfills the obligation for the second deviation reporting period (July 1 through December 31 of the previous year).

024 [25 Pa. Code §127.441]**Operating permit terms and conditions.**

[Additional authority for this permit condition is also derived from 25 Pa. Code § 127.511.]

(a) The permittee shall report malfunctions, emergencies or incidents of excess emissions to the Department. A malfunction is any sudden, infrequent, and not reasonably preventable failure of air pollution control equipment, process equipment, or a process to operate in a normal or usual manner. An emergency is any situation arising from sudden and reasonably unforeseeable events beyond the control of the owner or operator of a facility which requires immediate corrective action to restore normal operation and which causes the emission source to exceed emissions, due to unavoidable increases in emissions attributable to the situation. An emergency shall not include situations caused by improperly designed equipment, lack of preventive maintenance, careless or improper operation, or operator error.

**SECTION C. Site Level Requirements**

(b) When the malfunction, emergency or incident of excess emissions poses an imminent danger to the public health, safety, welfare, or environment, it shall be reported to the Department and the County Emergency Management Agency by telephone within one (1) hour after the discovery of the malfunction, emergency or incident of excess emissions. The owner or operator shall submit a written or emailed report of instances of such malfunctions, emergencies or incidents of excess emissions to the Department within three (3) business days of the telephone report.

(c) The report shall describe the following:

- (1) Name, permit or authorization number, and location of the facility;
- (2) Nature and cause of the malfunction, emergency or incident;
- (3) Date and time when the malfunction, emergency or incident was first observed;
- (4) Expected duration of excess emissions;
- (5) Estimated rate of emissions; and
- (6) Corrective actions or preventative measures taken.

(d) Any malfunction, emergency or incident of excess emissions that is not subject to the notice requirements of paragraph (b) of this condition shall be reported to the Department by telephone within 24 hours (or by 4:00 PM of the next business day, whichever is later) of discovery and in writing or by e-mail within five (5) business days of discovery. The report shall contain the same information required by paragraph (c), and any permit specific malfunction reporting requirements.

(e) During an emergency an owner or operator may continue to operate the source at their discretion provided they submit justification for continued operation of a source during the emergency and follow all the notification and reporting requirements in accordance with paragraphs (b)-(d), as applicable, including any permit specific malfunction reporting requirements.

(f) Reports regarding malfunctions, emergencies or incidents of excess emissions shall be submitted to the appropriate DEP Regional Office Air Program Manager.

(g) Any emissions resulted from malfunction or emergency are to be reported in the annual emissions inventory report, if the annual emissions inventory report is required by permit or authorization.

025 [25 Pa. Code §135.21]
Emission statements

The permittee shall, by March 1 of each year, submit an annual emission statement for the preceding calendar year.

VI. WORK PRACTICE REQUIREMENTS.

026 [25 Pa. Code §123.1]
Prohibition of certain fugitive emissions

A person responsible for any source specified in Condition #002 of this section shall take all reasonable actions to prevent particulate matter from becoming airborne. These actions shall include, but not be limited to, the following:

- (a). Use, where possible, of water or suitable chemicals, as approved by the Department, for control of dust in the demolition of buildings or structures, construction operations, the grading of roads, or the clearing of land.
- (b). Application of asphalt, water, or suitable chemicals, as approved by the Department, on dirt roads, material stockpiles and other surfaces which may give rise to airborne dusts.
- (c). Paving and maintenance of roadways.
- (d). Prompt removal of earth or other material from paved streets onto which earth or other material has been transported by trucking or earth moving equipment, erosion by water, or other means.

**SECTION C. Site Level Requirements****# 027 [25 Pa. Code §127.441]****Operating permit terms and conditions.**

[Additional authority for this permit condition is also derived from 25 Pa. Code § 127.512(h).]

(a). The permittee may not modify any source identified in Section A of this permit prior to obtaining Department approval, except those modifications authorized by Condition #017(g) of Section B of this permit.

(b). If an unauthorized modification of any source(s) occurs at this facility, this permit, as it pertains to the modified source(s), may be suspended and the source(s) may not be operated until authorized by the Department.

028 [25 Pa. Code §127.441]**Operating permit terms and conditions.**

[Additional authority for this permit condition is also derived from 25 Pa. Code § 127.512(h).]

The permittee shall immediately upon discovery implement measures, including the installation of air cleaning device(s), if necessary, to reduce the air contaminant emissions to within applicable limitations, if at any time the operation of the source(s) identified in Section A of this permit is causing the emission of air contaminants in excess of the limitations specified in, or established pursuant to, 25 Pa. Code Article III or any other applicable rule promulgated under the Clean Air Act as stated in this permit.

029 [25 Pa. Code §127.441]**Operating permit terms and conditions.**

[Additional authority for this permit condition is also derived from 25 Pa. Code §§ 127.511, 127.512(h) and §§ 129.91 - 129.95.]

The permittee shall ensure that the source(s) and air pollution control device(s), listed in Section A and Section G, where applicable, of this permit, are operated and maintained in a manner consistent with good operating and maintenance practices, and in accordance with manufacturers specifications.

VII. ADDITIONAL REQUIREMENTS.

No additional requirements exist except as provided in other sections of this permit including Section B (Title V General Requirements).

VIII. COMPLIANCE CERTIFICATION.

No additional compliance certifications exist except as provided in other sections of this permit including Section B (relating to Title V General Requirements).

IX. COMPLIANCE SCHEDULE.

No compliance milestones exist.

***** Permit Shield In Effect *****

**SECTION D. Source Level Requirements**

Source ID: 031

Source Name: CLEAVER BROOKS (B-901)

Source Capacity/Throughput:	14.600	MMBTU/HR	
	104.290	Gal/HR	#2 Oil
	13.900	MCF/HR	Natural Gas

Conditions for this source occur in the following groups: GROUP #1

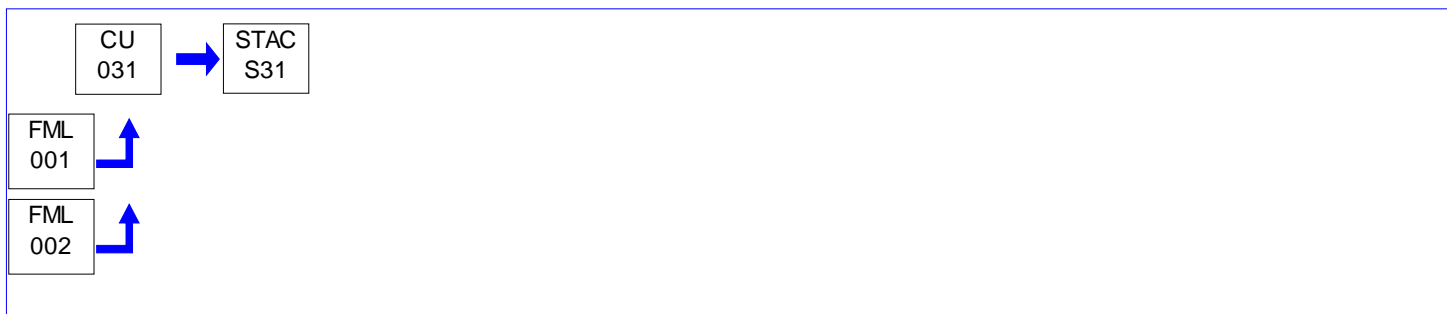
**I. RESTRICTIONS.**

No additional requirements exist except as provided in other sections of this permit including Section B (Title V General Requirements) and/or Section E (Source Group Restrictions).

II. TESTING REQUIREMENTS.

No additional testing requirements exist except as provided in other sections of this permit including Section B (Title V General Requirements) and/or Section E (Source Group Restrictions).

III. MONITORING REQUIREMENTS.

No additional monitoring requirements exist except as provided in other sections of this permit including Section B (Title V General Requirements) and/or Section E (Source Group Restrictions).

IV. RECORDKEEPING REQUIREMENTS.

No additional record keeping requirements exist except as provided in other sections of this permit including Section B (Title V General Requirements) and/or Section E (Source Group Restrictions).

V. REPORTING REQUIREMENTS.

No additional reporting requirements exist except as provided in other sections of this permit including Section B (Title V General Requirements) and/or Section E (Source Group Restrictions).

VI. WORK PRACTICE REQUIREMENTS.

No additional work practice requirements exist except as provided in other sections of this permit including Section B (Title V General Requirements) and/or Section E (Source Group Restrictions).

VII. ADDITIONAL REQUIREMENTS.

No additional requirements exist except as provided in other sections of this permit including Section B (Title V General Requirements) and/or Section E (Source Group Restrictions).

***** Permit Shield in Effect. *****

**SECTION D. Source Level Requirements**

Source ID: 032

Source Name: CLEAVER BROOKS (B-902)

Source Capacity/Throughput:	14.700	MMBTU/HR	
	104.290	Gal/HR	#2 Oil
	13.900	MCF/HR	Natural Gas

Conditions for this source occur in the following groups: GROUP #1

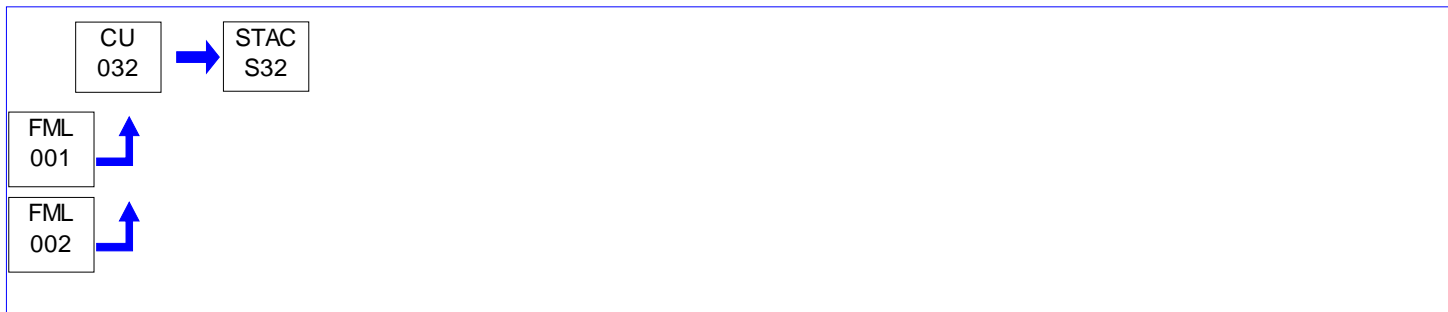
**I. RESTRICTIONS.**

No additional requirements exist except as provided in other sections of this permit including Section B (Title V General Requirements) and/or Section E (Source Group Restrictions).

II. TESTING REQUIREMENTS.

No additional testing requirements exist except as provided in other sections of this permit including Section B (Title V General Requirements) and/or Section E (Source Group Restrictions).

III. MONITORING REQUIREMENTS.

No additional monitoring requirements exist except as provided in other sections of this permit including Section B (Title V General Requirements) and/or Section E (Source Group Restrictions).

IV. RECORDKEEPING REQUIREMENTS.

No additional record keeping requirements exist except as provided in other sections of this permit including Section B (Title V General Requirements) and/or Section E (Source Group Restrictions).

V. REPORTING REQUIREMENTS.

No additional reporting requirements exist except as provided in other sections of this permit including Section B (Title V General Requirements) and/or Section E (Source Group Restrictions).

VI. WORK PRACTICE REQUIREMENTS.

No additional work practice requirements exist except as provided in other sections of this permit including Section B (Title V General Requirements) and/or Section E (Source Group Restrictions).

VII. ADDITIONAL REQUIREMENTS.

No additional requirements exist except as provided in other sections of this permit including Section B (Title V General Requirements) and/or Section E (Source Group Restrictions).

***** Permit Shield in Effect. *****

**SECTION D. Source Level Requirements**

Source ID: 037

Source Name: BOILER (B-904)

Source Capacity/Throughput:	9.850	MMBTU/HR	
	9.310	MCF/HR	Natural Gas
	68.400	Gal/HR	#2 Oil

Conditions for this source occur in the following groups: GROUP #1

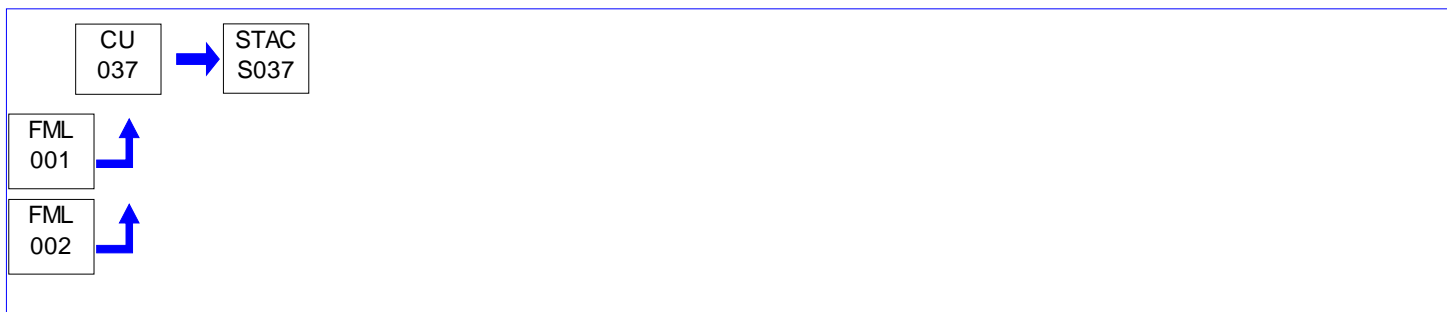
**I. RESTRICTIONS.**

No additional requirements exist except as provided in other sections of this permit including Section B (Title V General Requirements) and/or Section E (Source Group Restrictions).

II. TESTING REQUIREMENTS.

No additional testing requirements exist except as provided in other sections of this permit including Section B (Title V General Requirements) and/or Section E (Source Group Restrictions).

III. MONITORING REQUIREMENTS.

No additional monitoring requirements exist except as provided in other sections of this permit including Section B (Title V General Requirements) and/or Section E (Source Group Restrictions).

IV. RECORDKEEPING REQUIREMENTS.

No additional record keeping requirements exist except as provided in other sections of this permit including Section B (Title V General Requirements) and/or Section E (Source Group Restrictions).

V. REPORTING REQUIREMENTS.

No additional reporting requirements exist except as provided in other sections of this permit including Section B (Title V General Requirements) and/or Section E (Source Group Restrictions).

VI. WORK PRACTICE REQUIREMENTS.

No additional work practice requirements exist except as provided in other sections of this permit including Section B (Title V General Requirements) and/or Section E (Source Group Restrictions).

VII. ADDITIONAL REQUIREMENTS.

No additional requirements exist except as provided in other sections of this permit including Section B (Title V General Requirements) and/or Section E (Source Group Restrictions).

***** Permit Shield in Effect. *****

**SECTION D. Source Level Requirements**

Source ID: 110

Source Name: STRIPPING/HIVAC ON PAD A

Source Capacity/Throughput:

N/A

ACRYL/MON/S0LV.

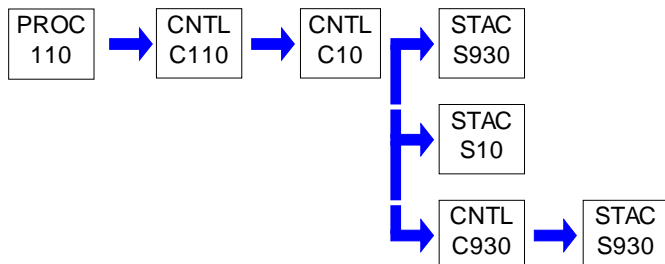
**I. RESTRICTIONS.****Emission Restriction(s).**

001 [25 Pa. Code §127.441]

Operating permit terms and conditions.

The total volatile organic compound (VOC) emission rate for this unit shall not exceed 6.9 lbs/hr and 30.2 tons in a 12-month rolling period when the Vilter is not operating.

II. TESTING REQUIREMENTS.

No additional testing requirements exist except as provided in other sections of this permit including Section B (Title V General Requirements).

III. MONITORING REQUIREMENTS.

002 [25 Pa. Code §127.441]

Operating permit terms and conditions.

[Additional authority for this permit condition is also derived from 40 C.F.R. §§ 64.3, 64.6, 64.7 and 71.6 (the CAM Plan).]

(a). The permittee shall continuously monitor the temperature of the outlet air from Source ID No. C10 (condenser) associated with this source.

(b). The temperature measurements for paragraph (a) above shall be taken at a frequency of 15-minute data points, at a minimum.

003 [25 Pa. Code §127.441]

Operating permit terms and conditions.

(a). The permittee shall monitor the temperature of the chilled water at least once per operating day.

(b). The permittee shall monitor the temperature of the cooling tower water at least once per operating day.

004 [25 Pa. Code §127.441]

Operating permit terms and conditions.

The permittee shall monitor the following on a weekly basis when this source is in operation:

(a). Amount of material processed.

(b). The hours of operation.

**SECTION D. Source Level Requirements****IV. RECORDKEEPING REQUIREMENTS.****# 005 [25 Pa. Code §127.441]****Operating permit terms and conditions.**

[Additional authority for this permit condition is also derived from 40 C.F.R. §§ 64.9 and 71.6 (the CAM Plan).]

- (a). The permittee shall continuously record the temperature of the outlet air from Source ID No. C10 (condenser) associated with this source using an electronic data acquisition system.
- (b). The temperature measurements recorded for paragraph (a) above shall be taken at a frequency of 15-minute data points, at a minimum.
- (c). Hourly averages of four 15-minute temperature readings shall be calculated to demonstrate compliance with applicable temperature limitations.

006 [25 Pa. Code §127.441]**Operating permit terms and conditions.**

[Additional authority for this permit condition is also derived from 40 C.F.R. §§ 64.9 and 71.6 (the CAM Plan).]

The permittee shall keep all recorded data of the temperature of the outlet air from the condenser (Source ID No. C10), any excursions, and any corrective actions taken to address excursions for a period of five (5) years, and the records shall be made available to the Department upon request.

007 [25 Pa. Code §127.441]**Operating permit terms and conditions.**

[Additional authority for this permit condition is also derived from 40 C.F.R. § 64.9.]

The permittee shall record actions taken to implement a QIP during a reporting period and all related actions including, but not limited to, repairs and maintenance performed on the control device and monitoring equipment.

008 [25 Pa. Code §127.441]**Operating permit terms and conditions.**

- (a). The permittee shall keep records of the temperature of the chilled water at least once per operating day.
- (b). The permittee shall keep records of the temperature of the cooling tower water at least once per operating day.

009 [25 Pa. Code §127.441]**Operating permit terms and conditions.**

The permittee shall calculate and record the following:

- (a). The maximum average hourly emission rate of the VOCs.
- (b). The total average daily emission rate of the VOCs.
- (c). The total emission rate of VOCs in a 12-month rolling period.
- (d). A copy of the manufacturer's specification for installation, operation, and maintenance of this source.
- (e). The permittee shall keep maintenance records for all work performed on this source.

Records shall be kept for a minimum of five (5) years and shall be made available to the Department upon request.

010 [25 Pa. Code §127.441]**Operating permit terms and conditions.**

The permittee shall keep records of the following on a weekly basis when this source is in operation:

- (a). Amount of material processed.
- (b). The hours of operation

**SECTION D. Source Level Requirements****V. REPORTING REQUIREMENTS.****# 011 [25 Pa. Code §127.441]****Operating permit terms and conditions.**

[Additional authority for this permit condition is also derived from 40 C.F.R. §§ 64.9 and 71.6 (the CAM Plan).]

Response Procedures for an Excursion

- (a). The permittee shall notify the Department within two (2) hours of becoming aware of an excursion.
- (b). The permittee shall investigate the problem and take corrective action.
- (c). The permittee shall provide a summary description of the problem and any corrective action taken in writing within two (2) days after the incident.

VI. WORK PRACTICE REQUIREMENTS.**# 012 [25 Pa. Code §127.441]****Operating permit terms and conditions.**

[Additional authority for this permit condition is also derived from 40 C.F.R. §§ 64.3, 64.6, 64.7 and 71.6 (the CAM Plan).]

- (a). The permittee shall operate and maintain a temperature measuring device, such as a thermocouple, RTD, or equivalent, to continuously monitor and subsequently record the air outlet temperature from Source ID No. C10 (condenser).
- (b). At least on an annual basis, the temperature measuring devices operated in paragraph (a) above shall be calibrated to within an accuracy of +/- 5 degrees Celcius being recorded using industry accepted standards.

013 [25 Pa. Code §127.441]**Operating permit terms and conditions.**

[Additional authority for this permit condition is also derived from 40 C.F.R. §§ 64.8 and 71.6 (the CAM Plan).]

- (a). As expeditiously as practicable, but not exceeding 60 days of the date of determination, the permittee shall implement a Quality Improvement Plan (QIP) if any of the following occurs:
 - (1). For properly and accurately collected data, accumulated excursions from the range of acceptable operating parameters that determine compliance for this source exceeding two (2) percent duration of the total operating time of the unit in a six (6) month reporting period.
 - (2). Six excursions from the acceptable operating parameters that determine compliance for this source in a six (6) month reporting period.
 - (3). The Department determines after reviewing all reported information for this source that the permittee has not responded acceptably to an excursion.
- (b). The permittee shall notify the Department if the period for completing the improvements contained in the QIP exceeds 180 days from the date on which the need to implement the QIP was determined.

014 [25 Pa. Code §127.441]**Operating permit terms and conditions.**

[Additional authority for this permit condition is also derived from 40 C.F.R. § 64.8.]

In accordance with with 40 C.F.R. § 64.8, the QIP shall include procedures for evaluating the control performance problems. Based on the results of the evaluation procedures, the permittee shall modify the QIP, and provide a copy to the Department, to include procedures for conducting more frequent or improved monitoring in conjunction with one or more of the following:

**SECTION D. Source Level Requirements**

- (a). Improved preventive maintenance practices.
- (b). Process operation changes.
- (c). Appropriate improvements to control methods.
- (d). Other steps appropriate to correct performance.

015 [25 Pa. Code §127.441]**Operating permit terms and conditions.**

[Additional authority for this permit condition is also derived from 40 C.F.R. § 64.8.]

Following the implementation of a QIP, the Department will require reasonable revisions to the QIP if the plan has failed to either:

- (a). Address the cause of the control device performance problem.
- (b). Provide adequate procedures for correcting control device performance problems in an expeditious manner in accordance with good air pollution control practices for minimizing emissions.

016 [25 Pa. Code §127.441]**Operating permit terms and conditions.**

[Additional authority for this permit condition is also derived from 40 C.F.R. § 64.8.]

Implementation of a QIP, shall not excuse the owner or operator of a source from compliance with any existing emission limitation or standard of any existing monitoring, testing, reporting, or recordkeeping requirement that may apply under any federal, state, or local laws or any other applicable requirements under the Clean Air Act.

017 [25 Pa. Code §127.441]**Operating permit terms and conditions.**

- (a). The permittee shall limit the maximum temperature of the chilled water to 20 degrees Celcius.
- (b). The permittee shall operate and maintain this source according to the manufacturer's specifications and good air pollution control practices.

VII. ADDITIONAL REQUIREMENTS.**# 018 [25 Pa. Code §127.441]****Operating permit terms and conditions.**

WHEN VILTER REFRIGERATED CONDENSER (Source ID No. 930) IS NOT OPERATING:

[Additional authority for this permit condition is also derived from 25 Pa. Code §§ 127.511, 127.512(h) and §§ 129.91 - 129.95 and 40 C.F.R. §§ 64.3 and 71.6 (the CAM Plan).]

- (a). When the Vilter Refrigerated Condenser (Source ID No. C930) associated with this source is not in operation, the air temperature leaving the final operating condenser shall not exceed 86 degrees F (30 degrees C)(hourly average).
- (b). For each time that the outlet air temperature for Source ID No. C10 (the condenser associated with this source) is greater then 86 degrees F (hourly average) and the Vilter Refrigerated Condenser associated with this source is not in operation, the incident shall be defined as an excursion for the purposes of the Compliance Assurance Monitoring (CAM) Plan for this source.
- (c) The source is allowed to operate without the Vilter Refrigerated Condenser (Source ID No. C930) operating only when the condenser is off line for maintenance or repair, and provided that the source is operating in compliance with the applicable requirements of this permit.

**SECTION D. Source Level Requirements****# 019 [25 Pa. Code §127.441]****Operating permit terms and conditions.**

The source consists of the Strippers located on Pad A:

S-149 with Primary Condenser C-149

S-151 with Primary Condenser C-157

S-153 with Primary Condenser C-156A and Secondary Condenser C-160

***** Permit Shield in Effect. *****

**SECTION D. Source Level Requirements**

Source ID: 111

Source Name: STRIPPING (S-207) PAD C

Source Capacity/Throughput: 4,000.000 Lbs/HR ACRYL/MON/SOLV/

Conditions for this source occur in the following groups: GROUP #5

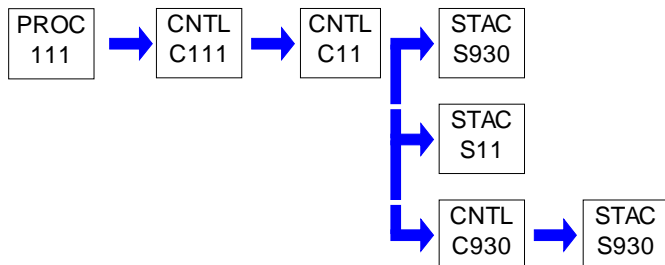
**I. RESTRICTIONS.****Emission Restriction(s).****# 001 [25 Pa. Code §127.441]****Operating permit terms and conditions.**

[Additional authority for this permit condition is also derived from 25 Pa. Code § 127.511/512(h)/129.91/92/93.]

The post-control volatile organic compound (VOC) emissions from this source shall be limited to 13 pounds per hour and 18 tons per year on a twelve month rolling basis when the Vilter is not operating.

II. TESTING REQUIREMENTS.

No additional testing requirements exist except as provided in other sections of this permit including Section B (Title V General Requirements) and/or Section E (Source Group Restrictions).

III. MONITORING REQUIREMENTS.**# 002 [25 Pa. Code §127.441]****Operating permit terms and conditions.**

[Additional authority for this permit condition is also derived from 25 Pa. Code §§ 127.511, 127.512(h) and §§ 129.91 - 129.95.]

(a). The permittee shall monitor and maintain equipment to measure the water flowrate to each condenser (C111 and C11) associated with this source.

(b). The permittee shall monitor and maintain temperature measuring and recording devices on:

- (1) the cooling water inlets and outlets to each condenser, and
- (2) the exhaust gas leaving each condenser (C111 and C11).

IV. RECORDKEEPING REQUIREMENTS.

No additional record keeping requirements exist except as provided in other sections of this permit including Section B (Title V General Requirements) and/or Section E (Source Group Restrictions).

V. REPORTING REQUIREMENTS.

No additional reporting requirements exist except as provided in other sections of this permit including Section B (Title V General Requirements) and/or Section E (Source Group Restrictions).

**SECTION D. Source Level Requirements****VI. WORK PRACTICE REQUIREMENTS.**

No additional work practice requirements exist except as provided in other sections of this permit including Section B (Title V General Requirements) and/or Section E (Source Group Restrictions).

VII. ADDITIONAL REQUIREMENTS.

003 [25 Pa. Code §127.441]

Operating permit terms and conditions.

WHEN VILTER REFRIGERATED CONDENSER (Source ID No. 930) IS NOT OPERATING:

[Additional authority for this permit condition is also derived from 25 Pa. Code §§ 127.511, 127.512(h) and §§ 129.91 - 129.95.]

(a) When the Vilter refrigerated condenser (Source ID C930) is off line for maintenance or repair, the air temperature leaving the condenser (Source ID C11) shall not exceed 77°F (25°C) (hourly average), nor shall the average temperature during the operation period exceed 70°F (21.11°C).

(b) The source is allowed to operate without the Vilter Refrigerated Condenser (Source ID No. C930) operating only when the condenser is off line for maintenance or repair, and provided that the source is operating in compliance with the applicable requirements of this permit.

***** Permit Shield in Effect. *****

**SECTION D. Source Level Requirements**

Source ID: 112

Source Name: STRIPPING (S-212) PAD C

Source Capacity/Throughput: 4,000.000 Lbs/HR ACRYL/MON/SOLV.

Conditions for this source occur in the following groups: GROUP #5

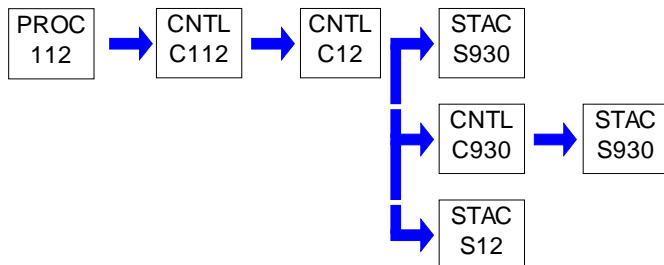
**I. RESTRICTIONS.****Emission Restriction(s).****# 001 [25 Pa. Code §127.441]
Operating permit terms and conditions.**

[Additional authority for this permit condition is also derived from 25 Pa. Code § 127.511/512(h)/129.91/92/93.]

The post-control volatile organic compound (VOC) emissions from this source shall be limited to 10 pounds per hour and 35.2 tons per year on a 12 month rolling basis when the Vilter is not operating.

II. TESTING REQUIREMENTS.

No additional testing requirements exist except as provided in other sections of this permit including Section B (Title V General Requirements) and/or Section E (Source Group Restrictions).

III. MONITORING REQUIREMENTS.**# 002 [25 Pa. Code §127.441]
Operating permit terms and conditions.**

[Additional authority for this permit condition is also derived from 25 Pa. Code §§ 127.511, 127.512(h) and §§ 129.91 - 129.95.]

(a) The permittee shall monitor and maintain equipment to measure the water flow rate to each condenser (C112 and C12) associated with this source.

(b) The permittee shall monitor and maintain temperature measuring and recording devices on the cooling water inlets and outlets to each condenser and the exhaust gas leaving each condenser (C112 and C12).

**# 003 [25 Pa. Code §127.441]
Operating permit terms and conditions.**

[Additional authority for this permit condition is also derived from 40 CFR §§ 64.3, 64.6, 64.7 and 71.6 (the CAM Plan).]

(a). The permittee shall continuously monitor the exhaust gas temperature leaving Source ID C12 (condenser).

(b). The temperature measurements for paragraph (a) above shall be taken at a frequency of 15-minute data points, at a minimum.

**SECTION D. Source Level Requirements****IV. RECORDKEEPING REQUIREMENTS.****# 004 [25 Pa. Code §127.441]****Operating permit terms and conditions.**

[Additional authority for this permit condition is also derived from 40 C.F.R. § 64.9.]

The permittee shall record actions taken to implement a QIP during a reporting period and all related actions including, but not limited to, repairs and maintenance performed on the control device and monitoring equipment.

005 [25 Pa. Code §127.441]**Operating permit terms and conditions.**

[Additional authority for this permit condition is also derived from 25 Pa. Code §§ 127.511, 127.512(h) and §§ 129.91 - 129.95.]

The permittee shall keep records of the cooling water inlet and outlet temperature for each condenser at least once per shift.

006 [25 Pa. Code §127.441]**Operating permit terms and conditions.**

[Additional authority for this permit condition is also derived from 40 C.F.R. §§ 64.9 and 71.6 (the CAM Plan).]

(a). The permittee shall continuously record the temperature of the outlet air from Source ID No. C12 (condenser) associated with this source using an electronic data acquisition system.

(b). The temperature measurements recorded for paragraph (a) above shall be taken at a frequency of 15-minute data points, at a minimum.

(c). Hourly averages of four 15-minute temperature readings shall be calculated to demonstrate compliance with applicable temperature limitations.

007 [25 Pa. Code §127.441]**Operating permit terms and conditions.**

[Additional authority for this permit condition is also derived from 40 C.F.R. §§ 64.9 and 71.6 (the CAM Plan).]

The permittee shall keep all recorded data of the outlet air temperature from the condenser (Source ID No. C12), any excursions, and any corrective actions taken to address excursions for a period of five (5) years, and the records shall be made available to the Department upon request.

V. REPORTING REQUIREMENTS.**# 008 [25 Pa. Code §127.441]****Operating permit terms and conditions.**

[Additional authority for this permit condition is also derived from 40 C.F.R. §§ 64.9 and 71.6 (the CAM Plan).]

Response Procedures for an Excursion

(a). The permittee shall notify the Department within two (2) hours of becoming aware of an excursion.

(b). The permittee shall investigate the problem and take corrective action.

(c). The permittee shall provide a summary description of the problem and any corrective action taken in writing within two (2) days after the incident.

**SECTION D. Source Level Requirements****VI. WORK PRACTICE REQUIREMENTS.****# 009 [25 Pa. Code §127.441]****Operating permit terms and conditions.**

[Additional authority for this permit condition is also derived from 40 C.F.R. § 64.8.]

Following the implementation of a QIP, the Department will require reasonable revisions to the QIP if the plan has failed to either:

- (a). Address the cause of the control device performance problem.
- (b). Provide adequate procedures for correcting control device performance problems in an expeditious manner in accordance with good air pollution control practices.

010 [25 Pa. Code §127.441]**Operating permit terms and conditions.**

[Additional authority for this permit condition is also derived from 40 C.F.R. § 64.8.]

Implementation of a QIP, shall not excuse the owner or operator of a source from compliance with any existing emission limitation or standard of any existing monitoring, testing, reporting, or recordkeeping requirement that may apply under any federal, state, or local laws or any other applicable requirements under the Clean Air Act.

011 [25 Pa. Code §127.441]**Operating permit terms and conditions.**

[Additional authority for this permit condition is also derived from 40 C.F.R. §§ 64.3, 64.6, 64.7 and 71.6 (the CAM Plan).]

- (a). The permittee shall operate and maintain a temperature measuring device, such as a thermocouple, RTD, or equivalent, to continuously monitor and subsequently record the air outlet temperature from Source ID C12 (condenser).
- (b). At least on an annual basis, the temperature measuring devices operated in paragraph (a) above shall be calibrated to within an accuracy of +/- 5°C being recorded using industry accepted standards.

012 [25 Pa. Code §127.441]**Operating permit terms and conditions.**

[Additional authority for this permit condition is also derived from 40 C.F.R. §§ 64.8 and 71.6 (the CAM Plan).]

- (a). As expeditiously as practicable, but not exceeding 60 days of the date of determination, the permittee shall implement a Quality Improvement Plan (QIP) if any of the following occurs:
 - (1). For properly and accurately collected data, accumulated excursions from the range of acceptable operating parameters that determine compliance for this source exceeding two (2) percent duration of the total operating time of the unit in a six (6) month reporting period.
 - (2). Six excursions from the acceptable operating parameters that determine compliance for this source in a six (6) month reporting period.
 - (3). The Department determines after reviewing all reported information for this source that the permittee has not responded acceptably to an excursion.
- (b). The permittee shall notify the Department if the period for completing the improvements contained in the QIP exceeds 180 days from the date on which the need to implement the QIP was determined.

013 [25 Pa. Code §127.441]**Operating permit terms and conditions.**

[Additional authority for this permit condition is also derived from 40 C.F.R. § 64.8.]

**SECTION D. Source Level Requirements**

In accordance with with 40 C.F.R. 64.8, the QIP shall include procedures for evaluating the control performance problems. Based on the results of the evaluation procedures, the permittee shall modify the QIP, and provide a copy to the Department, to include procedures for conducting more frequent or improved monitoring in conjunction with one or more of the following:

- (a). Improved preventive maintenance practices.
- (b). Process operation changes.
- (c). Appropriate improvements to control methods.
- (d). Other steps appropriate to correct performance.

VII. ADDITIONAL REQUIREMENTS.

014 [25 Pa. Code §127.441]

Operating permit terms and conditions.

WHEN VILTER REFRIGERATED CONDENSER (Source ID No. 930) IS NOT OPERATING:

[Additional authority for this permit condition is also derived from 25 Pa. Code §§ 127.511, 127.512(h) and §§ 129.91 - 129.95 and 40 C.F.R. §§ 64.3 and 71.6 (the CAM Plan).]

- (a). When the Vilter refrigerated condenser (Source ID C930) is off line for maintenance or repair, the air temperature leaving the condenser (Source ID C12) shall not exceed 70°F (21.11°C) during the operation period.
- (b). For each time that the condenser (Source ID C12) outlet air temperature is greater then 77°F (hourly average), the incident shall be defined as an excursion for the purposes of the Compliance Assurance Monitoring (CAM) Plan for this source.
- (c). The source is allowed to operate without the Vilter Refrigerated Condenser (Source ID No. C930) operating only when the condenser is off line for maintenance or repair, and provided that the source is operating in compliance with the applicable requirements of this permit.

***** Permit Shield in Effect. *****

**SECTION D. Source Level Requirements**

Source ID: 115

Source Name: STRIPPING (S-1101) PAD H

Source Capacity/Throughput: 10,000.000 Lbs/HR

ACRYL/MON/SOLV.

Conditions for this source occur in the following groups: GROUP #4
GROUP #5

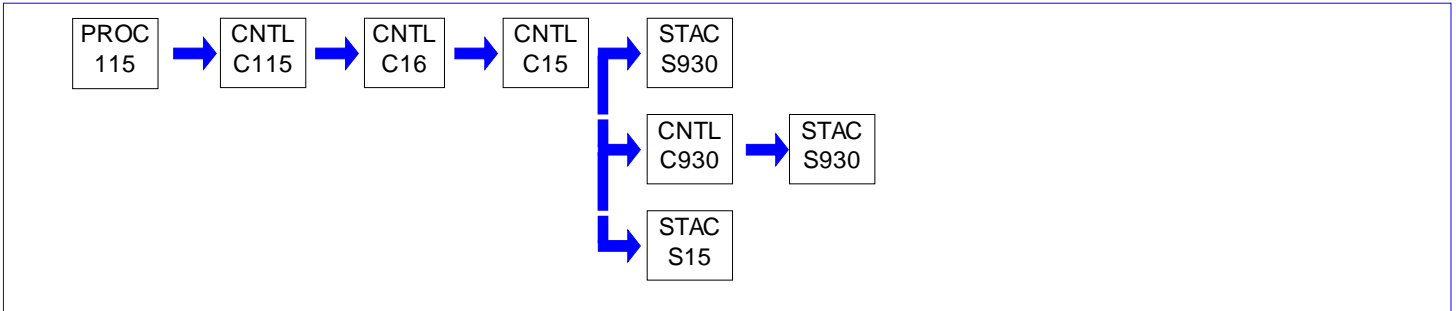
**I. RESTRICTIONS.**

No additional requirements exist except as provided in other sections of this permit including Section B (Title V General Requirements) and/or Section E (Source Group Restrictions).

II. TESTING REQUIREMENTS.

No additional testing requirements exist except as provided in other sections of this permit including Section B (Title V General Requirements) and/or Section E (Source Group Restrictions).

III. MONITORING REQUIREMENTS.**# 001 [25 Pa. Code §127.441]****Operating permit terms and conditions.**

[Additional authority for this permit condition is also derived from 40 C.F.R. §§ 64.3, 64.6, 64.7 and 71.6 (the CAM Plan).]

- (a). The permittee shall continuously monitor the temperature of the outlet air from Source ID No. C15 (condenser) associated with this source.
- (b). The temperature measurements for paragraph (a) above shall be taken at a frequency of 15-minute data points, at a minimum.

IV. RECORDKEEPING REQUIREMENTS.**# 002 [25 Pa. Code §127.441]****Operating permit terms and conditions.**

[Additional authority for this permit condition is also derived from 40 C.F.R. §§ 64.9 and 71.6 (the CAM Plan).]

- (a). The permittee shall continuously record the temperature of the outlet air from Source ID No. C15 (condenser) associated with this source using an electronic data acquisition system.
- (b). The temperature measurements recorded for paragraph (a) above shall be taken at a frequency of 15-minute data points, at a minimum.
- (d). Hourly averages of four 15-minute temperature readings shall be calculated to demonstrate compliance with applicable temperature limitations.

**SECTION D. Source Level Requirements****# 003 [25 Pa. Code §127.441]****Operating permit terms and conditions.**

[Additional authority for this permit condition is also derived from 40 C.F.R. §§ 64.9 and 71.6 (the CAM Plan).]

The permittee shall keep all recorded data of the outlet air temperature from the condenser (Source ID No. C15), any excursions, and any corrective actions taken to address excursions for a period of five (5) years, and the records shall be made available to the Department upon request.

004 [25 Pa. Code §127.441]**Operating permit terms and conditions.**

[Additional authority for this permit condition is also derived from 40 C.F.R. § 64.9.]

The permittee shall record actions taken to implement a QIP during a reporting period and all related actions including, but not limited to, repairs and maintenance performed on the control device and monitoring equipment.

V. REPORTING REQUIREMENTS.**# 005 [25 Pa. Code §127.441]****Operating permit terms and conditions.**

[Additional authority for this permit condition is also derived from 40 C.F.R. §§ 64.9 and 71.6 (the CAM Plan).]

Response Procedures for an Excursion

- (a). The permittee shall notify the Department within two (2) hours of becoming aware of an excursion.
- (b). The permittee shall investigate the problem and take corrective action.
- (c). The permittee shall provide a summary description of the problem and any corrective action taken in writing within two (2) days after the incident.

VI. WORK PRACTICE REQUIREMENTS.**# 006 [25 Pa. Code §127.441]****Operating permit terms and conditions.**

[Additional authority for this permit condition is also derived from 40 C.F.R. §§ 64.3, 64.6, 64.7 and 71.6 (the CAM Plan).]

- (a). The permittee shall operate and maintain a temperature measuring device, such as a thermocouple, RTD, or equivalent, to continuously monitor and subsequently record the air outlet temperature from Source ID No. C15 (condenser).
- (b). At least on an annual basis, the temperature measuring devices operated in paragraph (a) above shall be calibrated to within an accuracy of +/- 5 degrees Celcius being recorded using industry accepted standards.

007 [25 Pa. Code §127.441]**Operating permit terms and conditions.**

[Additional authority for this permit condition is also derived from 40 C.F.R. §§ 64.8 and 71.6 (the CAM Plan).]

- (a). As expeditiously as practicable, but not exceeding 60 days of the date of determination, the permittee shall implement a Quality Improvement Plan (QIP) if any of the following occurs:
 - (1). For properly and accurately collected data, accumulated excursions from the range of acceptable operating parameters that determine compliance for this source exceeding two (2) percent duration of the total operating time of the

**SECTION D. Source Level Requirements**

unit in a six (6) month reporting period.

(2). Six excursions from the acceptable operating parameters that determine compliance for this source in a six (6) month reporting period.

(3). The Department determines after reviewing all reported information for this source that the permittee has not responded acceptably to an excursion.

(b). The permittee shall notify the Department if the period for completing the improvements contained in the QIP exceeds 180 days from the date on which the need to implement the QIP was determined.

008 [25 Pa. Code §127.441]**Operating permit terms and conditions.**

[Additional authority for this permit condition is also derived from 40 C.F.R. § 64.8.]

In accordance with with 40 C.F.R. 64.8, the QIP shall include procedures for evaluating the control performance problems. Based on the results of the evaluation procedures, the permittee shall modify the QIP, and provide a copy to the Department, to include procedures for conducting more frequent or improved monitoring in conjunction with one or more of the following:

- (a). Improved preventive maintenance practices.
- (b). Process operation changes.
- (c). Appropriate improvements to control methods.
- (d). Other steps appropriate to correct performance.

009 [25 Pa. Code §127.441]**Operating permit terms and conditions.**

[Additional authority for this permit condition is also derived from 40 C.F.R. § 64.8.]

Following the implementation of a QIP, the Department will require reasonable revisions to the QIP if the plan has failed to either:

- (a). Address the cause of the control device performance problem.
- (b). Provide adequate procedures for correcting control device performance problems in an expeditious manner in accordance with good air pollution control practices for minimizing emissions.

010 [25 Pa. Code §127.441]**Operating permit terms and conditions.**

[Additional authority for this permit condition is also derived from 40 C.F.R. § 64.8.]

Implementation of a QIP, shall not excuse the owner or operator of a source from compliance with any existing emission limitation or standard of any existing monitoring, testing, reporting, or recordkeeping requirement that may apply under any federal, state, or local laws or any other applicable requirements under the Clean Air Act.

VII. ADDITIONAL REQUIREMENTS.**# 011 [25 Pa. Code §127.441]****Operating permit terms and conditions.**

WHEN VILTER REFRIGERATED CONDENSER (Source ID No. 930) IS NOT OPERATING:

[Additional authority for this permit condition is also derived from 25 Pa. Code §§ 127.511, 127.512(h) and §§ 129.91 - 129.95 and 40 C.F.R. §§ 64.3 and 71.6 (the CAM Plan).]

- (a). The air temperature leaving the final operating condenser when the Vilter Refrigerated Condenser (Source ID No.

**SECTION D. Source Level Requirements**

C930) is not in operation shall not exceed 85 degrees F (29.4 degrees C)(hourly average).Each final operating condenser shall be equipped with a temperature alarm.

(b). For each time that the outlet air temperature for Source ID No. C15 (the condenser associated with this source) is greater than 85 degrees F (hourly average) and the Vilter Refrigerated Condenser (Source ID No. 930) is not in operation, the incident shall be defined as an excursion for the purposes of the Compliance Assurance Monitoring (CAM) Plan for this source.

(c). The source is allowed to operate without the Vilter Refrigerated Condenser (Source ID No. C930) operating only when the condenser is off line for maintenance or repair, and provided that the source is operating in compliance with the applicable requirements of this permit.

***** Permit Shield in Effect. *****

**SECTION D. Source Level Requirements**

Source ID: 117

Source Name: UTILITY VACUUMS

Source Capacity/Throughput:

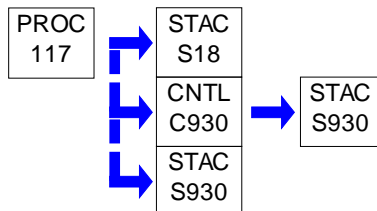
**I. RESTRICTIONS.****Control Device Efficiency Restriction(s).****# 001 [25 Pa. Code §127.441]****Operating permit terms and conditions.**

(a). The temperature of the exhaust gas leaving the Vilter refrigerated condenser (Source ID No. C930) shall be maintained below 10 degrees Fahrenheit as a monthly average when both the sources and the Vilter refrigerated condenser are operating.

(b). The source is allowed to operate without the Vilter refrigerated condenser (Source ID No. C930) operating only when the condenser is off line for maintenance or repair, and provided that the source is operating in compliance with the applicable requirements of this permit.

II. TESTING REQUIREMENTS.**# 002 [25 Pa. Code §127.441]****Operating permit terms and conditions.**

The permittee shall conduct a stack test to determine the Vilter Refrigerated Condenser (Source ID No. C930) removal efficiency once per permit term, but no less frequent than once every five (5) years.

III. MONITORING REQUIREMENTS.**# 003 [25 Pa. Code §127.441]****Operating permit terms and conditions.**

(a). The Vilter refrigerated condenser (Source ID No. C930) shall be equipped with a temperature monitoring and recording device to continuously measure and record the temperature of the exhaust gas leaving the condenser.

(b). The permittee shall monitor and record the source operating hours with indications that the Vilter refrigerated condenser (Source ID No. C930) is or is not operating.

IV. RECORDKEEPING REQUIREMENTS.**# 004 [25 Pa. Code §127.441]****Operating permit terms and conditions.**

(a). The permittee shall keep the following records:

(i). The temperature of the exhaust gas leaving the Vilter refrigerate condenser (Source ID No. C930) on a daily basis and a monthly average basis.

(ii). The toluene emissions on a monthly basis and 12-month rolling sum.

(iii). The Vilter refrigerated condenser (Source ID No. C930) operating hours.

**SECTION D. Source Level Requirements**

(iv). The source operating hours with indications of with or without the operation of the Vilter refrigerated condenser (Source ID No. C930).

(b). The permittee shall use the Department approved methods to calculate the source VOC and HAP emissions with and without the Vilter refrigerated condenser (Source ID No. C930) operating, respectively.

V. REPORTING REQUIREMENTS.

No additional reporting requirements exist except as provided in other sections of this permit including Section B (Title V General Requirements).

VI. WORK PRACTICE REQUIREMENTS.

005 [25 Pa. Code §127.441]
Operating permit terms and conditions.

[Additional authority for this permit condition is also derived from 25 Pa. Code § 127.511/512(h)/129.91/92/93.]

The utility vacuum shall be used only when materials are transferred from one process unit to another.

The utility vacuum shall be operated according to manufacturers specifications. The sources shall also be operated and maintained in accordance with good air pollution control practices.

VII. ADDITIONAL REQUIREMENTS.

No additional requirements exist except as provided in other sections of this permit including Section B (Title V General Requirements).

***** Permit Shield in Effect. *****

**SECTION D. Source Level Requirements**

Source ID: 124

Source Name: FUGITIVE VOC EMISSIONS

Source Capacity/Throughput:

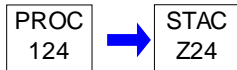
**I. RESTRICTIONS.**

No additional requirements exist except as provided in other sections of this permit including Section B (Title V General Requirements).

II. TESTING REQUIREMENTS.

No additional testing requirements exist except as provided in other sections of this permit including Section B (Title V General Requirements).

III. MONITORING REQUIREMENTS.

No additional monitoring requirements exist except as provided in other sections of this permit including Section B (Title V General Requirements).

IV. RECORDKEEPING REQUIREMENTS.

No additional record keeping requirements exist except as provided in other sections of this permit including Section B (Title V General Requirements).

V. REPORTING REQUIREMENTS.

No additional reporting requirements exist except as provided in other sections of this permit including Section B (Title V General Requirements).

VI. WORK PRACTICE REQUIREMENTS.

No additional work practice requirements exist except as provided in other sections of this permit including Section B (Title V General Requirements).

VII. ADDITIONAL REQUIREMENTS.**# 001 [25 Pa. Code §127.441]****Operating permit terms and conditions.**

Within 30 days of the issuance of this permit, the permittee shall provide to the Department a list of all the elements and their descriptions that are included in this source. The permittee shall maintain these records and make them available upon the request of the Department.

***** Permit Shield in Effect. *****

**SECTION D. Source Level Requirements**

Source ID: 201

Source Name: ESTERIFICATION - PAD C (R201, R202, R204, R205)

Source Capacity/Throughput:

N/A

ACRYL/MON/SOLV.

Conditions for this source occur in the following groups: GROUP #4
GROUP #5

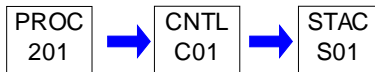
**I. RESTRICTIONS.****Emission Restriction(s).**

001 [25 Pa. Code §127.441]

Operating permit terms and conditions.

The total VOC emissions connected to the C203 condenser shall not exceed 16.0 tons per year on a 12-month rolling sum basis.

II. TESTING REQUIREMENTS.

No additional testing requirements exist except as provided in other sections of this permit including Section B (Title V General Requirements) and/or Section E (Source Group Restrictions).

III. MONITORING REQUIREMENTS.

002 [25 Pa. Code §127.441]

Operating permit terms and conditions.

[Additional authority for this permit condition is also derived from 25 Pa. Code §§ 127.511, 127.512(h) and §§ 129.91 - 129.95.]

The temperature of the primary condenser associated with this source shall be monitored every half hour, while this source is operated.

IV. RECORDKEEPING REQUIREMENTS.

003 [25 Pa. Code §127.441]

Operating permit terms and conditions.

The permittee shall keep annual records for each inspection performed on the conservation vents associated with the equipment listed under this source. If there is any leakage, note the date and the corrective action taken.

004 [25 Pa. Code §127.441]

Operating permit terms and conditions.

[Additional authority for this permit condition is also derived from 25 Pa. Code §§ 127.511, 127.512(h) and §§ 129.91 - 129.95.]

The temperature of the primary condenser associated with this source shall be recorded every half hour, while this source is operated.

V. REPORTING REQUIREMENTS.

No additional reporting requirements exist except as provided in other sections of this permit including Section B (Title V General Requirements) and/or Section E (Source Group Restrictions).

**SECTION D. Source Level Requirements****VI. WORK PRACTICE REQUIREMENTS.****# 005 [25 Pa. Code §127.441]****Operating permit terms and conditions.**

The permittee shall perform annually inspections and preventative maintenance of the conservation vents for Washers (W-203 and W-211) and the Reactor/Washer (R/W-206) to keep leakage to a minimum.

VII. ADDITIONAL REQUIREMENTS.**# 006 [25 Pa. Code §127.441]****Operating permit terms and conditions.**

Source ID #201 consists of the following equipment:

- (a). Four Reactors (R-202, R-204, R-205, R201)
- (b). Four Primary Condensor (C-202, C-204, C-205, C201) - these condensers are used to recover reactants and products from the effluent stream of the reactor for recycle back through the reactor.
- (c). Two Washers (W-203, W-211)
- (d). Reactor/Washer (R/W-206)

***** Permit Shield in Effect. *****

**SECTION D. Source Level Requirements**

Source ID: 202

Source Name: ESTERIFICATION - PAD A (R150, R151, R154, R155)

Source Capacity/Throughput:

N/A

ACRYL/MON/SOLV.

Conditions for this source occur in the following groups: GROUP #4
GROUP #5

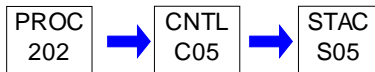
**I. RESTRICTIONS.****Emission Restriction(s).**

001 [25 Pa. Code §127.441]

Operating permit terms and conditions.

The total VOC emissions connected to the C-162 condenser shall not exceed 18.5 tons per year on a 12-month rolling sum basis.

II. TESTING REQUIREMENTS.

No additional testing requirements exist except as provided in other sections of this permit including Section B (Title V General Requirements) and/or Section E (Source Group Restrictions).

III. MONITORING REQUIREMENTS.

No additional monitoring requirements exist except as provided in other sections of this permit including Section B (Title V General Requirements) and/or Section E (Source Group Restrictions).

IV. RECORDKEEPING REQUIREMENTS.

No additional record keeping requirements exist except as provided in other sections of this permit including Section B (Title V General Requirements) and/or Section E (Source Group Restrictions).

V. REPORTING REQUIREMENTS.

No additional reporting requirements exist except as provided in other sections of this permit including Section B (Title V General Requirements) and/or Section E (Source Group Restrictions).

VI. WORK PRACTICE REQUIREMENTS.

002 [25 Pa. Code §127.441]

Operating permit terms and conditions.

The permittee shall perform annually inspections and preventative maintenance of the conservation vents for washers (W-152 and W-162) to keep leakage to a minimum.

VII. ADDITIONAL REQUIREMENTS.

003 [25 Pa. Code §127.441]

Operating permit terms and conditions.

Source ID #202 consists of the following equipment:

(a). Four Reactors (R-150, R-151, R-154, R155)

(b). Four Primary Condensers (C-150, C-151, C-154, C155) - these condensers are used to recover reactants and products from the effluent stream of the reactor for recycle back through the reactor.

**SECTION D. Source Level Requirements**

(c). Two Washers (W-152, W-162)

***** Permit Shield in Effect. *****

**SECTION D. Source Level Requirements**

Source ID: 203

Source Name: ESTERIFICATION - PAD H (R1101, R1151, R1171)

Source Capacity/Throughput: 11,100.000 Lbs/HR ACRYL/MON/SOLV.

Conditions for this source occur in the following groups: GROUP #5

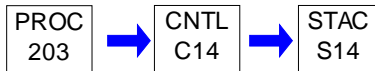
**I. RESTRICTIONS.****Emission Restriction(s).****# 001 [25 Pa. Code §127.441]****Operating permit terms and conditions.**

- (1) The volatile organic compounds (VOC) emissions from reactor R-1171 shall not exceed 2.32 tons per year on a 12-month rolling sum basis.
- (2) The hazardous air pollutants (HAP) emissions from reactor R-1171 shall not exceed 0.80 tons per year on a 12-month rolling sum basis.

002 [25 Pa. Code §127.441]**Operating permit terms and conditions.**

[Additional authority for this permit condition is also derived from 25 Pa. Code §§ 127.511, 127.512(h) and §§ 129.91 - 129.95.]

- (a). The total VOC emissions from sources connected to the C14 condenser shall not exceed 8.86 tons per year on a 12-month rolling sum basis.

Control Device Efficiency Restriction(s).**# 003 [25 Pa. Code §127.441]****Operating permit terms and conditions.**

[Additional authority for this permit condition is also derived from 25 Pa. Code §§ 127.511, 127.512(h) and §§ 129.91 - 129.95 and 40 C.F.R. §§ 64.3 and 71.6 (the CAM Plan).]

- (a). The exhaust gas temperature leaving the Vent Condenser (Source ID C14) shall not exceed 85 °F (29.4 °C) (hourly average).
- (b). For each time that the exhaust gas temperature leaving Source ID C14 is greater than 85 °F (hourly average), the incident shall be defined as an excursion for the purposes of the Compliance Assurance Monitoring (CAM) Plan for this source.

004 [25 Pa. Code §127.441]**Operating permit terms and conditions.**

[Additional authority for this permit condition is also derived from 25 Pa. Code §§ 127.511, 127.512(h) and §§ 129.91 - 129.95.]

The Vent Condenser, Source ID C14, shall be equipped with a temperature monitoring and alarm device.

II. TESTING REQUIREMENTS.

No additional testing requirements exist except as provided in other sections of this permit including Section B (Title V General Requirements) and/or Section E (Source Group Restrictions).

**SECTION D. Source Level Requirements****III. MONITORING REQUIREMENTS.****# 005 [25 Pa. Code §127.441]****Operating permit terms and conditions.**

The permittee shall monitor the following for this source on a daily basis, when this source is in operation:

- (a). The flow rate of air into this source (Reactors/Washers).
- (b). The temperature of the source (Reactors/Washers).
- (c). The exhaust gas temperature leaving the Vent Condenser (Source ID C14).

006 [25 Pa. Code §127.441]**Operating permit terms and conditions.**

[Additional authority for this permit condition is also derived from 40 C.F.R. §§ 64.3, 64.6, 64.7 and 71.6 (the CAM Plan).]

- (a). The permittee shall continuously monitor the exhaust gas temperature leaving Source ID C14 (condenser).
- (b). The temperature measurements for paragraph (a) above shall be taken at a frequency of 15-minute data points, at a minimum.

IV. RECORDKEEPING REQUIREMENTS.**# 007 [25 Pa. Code §127.441]****Operating permit terms and conditions.**

[Additional authority for this permit condition is also derived from 25 Pa. Code §§ 127.511, 127.512(h) and §§ 129.91 - 129.95.]

The permittee shall keep records of the condenser's maintenance and repair records. These records shall be maintained on site and be available for the Department to review upon request.

008 [25 Pa. Code §127.441]**Operating permit terms and conditions.**

(a). The permittee shall keep records of the following for this source on a daily basis, when this source is in operation:

- (1). The flow rate of air into this source (Reactors/Washers).
- (2). The temperature of the source (Reactors/Washers).
- (3). The exhaust gas temperature leaving the Vent Condenser (Source ID C14).

(b). The permittee shall calculate and record the VOC emissions from this source on a monthly basis and a 12-month rolling basis.

(c). The permittee shall calculate and record the VOC and HAP emissions from reactor R-1171 on a monthly basis and a 12-month rolling basis.

009 [25 Pa. Code §127.441]**Operating permit terms and conditions.**

[Additional authority for this permit condition is also derived from 40 C.F.R. §§ 64.9 and 71.6 (the CAM Plan).]

(a). The permittee shall continuously record the exhaust gas temperature leaving Source ID C14 (condenser) using an electronic data acquisition system.

(b). The temperature measurements recorded for paragraph (a) above shall be taken at a frequency of 15-minute data points, at a minimum.

(c). Hourly averages of four 15-minute temperature readings shall be calculated to demonstrate compliance with applicable temperature limitations.

010 [25 Pa. Code §127.441]**Operating permit terms and conditions.**

[Additional authority for this permit condition is also derived from 40 C.F.R. §§ 64.9 and 71.6 (the CAM Plan).]

**SECTION D. Source Level Requirements**

The permittee shall keep all recorded data of the exhaust gas temperature leaving the Vent Condenser (Source ID C14), any excursions, and any corrective actions taken to address excursions for a period of five (5) years, and the records shall be made available to the Department upon request.

011 [25 Pa. Code §127.441]

Operating permit terms and conditions.

[Additional authority for this permit condition is also derived from 40 C.F.R. § 64.9.]

The permittee shall record actions taken to implement a QIP during a reporting period and all related actions including, but not limited to, repairs and maintenance performed on the control device and monitoring equipment.

012 [25 Pa. Code §127.441]

Operating permit terms and conditions.

The permittee shall keep annually records for each inspection performed on the conservation vents associated with the equipment listed under this source. If there is any leakage, note the date and the corrective action taken.

V. REPORTING REQUIREMENTS.

013 [25 Pa. Code §127.441]

Operating permit terms and conditions.

[Additional authority for this permit condition is also derived from 40 C.F.R. §§ 64.9 and 71.6 (the CAM Plan).]

Response Procedures for an Excursion

- (a). The permittee shall notify the Department within two (2) hours of becoming aware of an excursion.
- (b). The permittee shall investigate the problem and take corrective action.
- (c). The permittee shall provide a summary description of the problem and any corrective action taken in writing within two(2) days after the incident.

VI. WORK PRACTICE REQUIREMENTS.

014 [25 Pa. Code §127.441]

Operating permit terms and conditions.

The permittee shall perform annual inspections and preventative maintenance of the conservation vents to keep leakage to a minimum.

015 [25 Pa. Code §127.441]

Operating permit terms and conditions.

[Additional authority for this permit condition is also derived from 40 CFR §§ 64.3, 64.6, 64.7 and 71.6 (the CAM Plan).]

- (a). The permittee shall operate and maintain a temperature measuring device, such as a thermocouple, RTD, or equivalent, to continuously monitor and subsequently record the exhaust gas temperature leaving the Vent Condenser (Source ID C14).
- (b). At least on an annual basis, the temperature measuring devices operated in paragraph (a) above shall be calibrated to within an accuracy of +/- 5 °C being recorded using industry accepted standards.

016 [25 Pa. Code §127.441]

Operating permit terms and conditions.

[Additional authority for this permit condition is also derived from 40 CFR §§ 64.8 and 71.6 (the CAM Plan).]

- (a). As expeditiously as practicable, but not exceeding 60 days of the date of determination, the permittee shall implement a Quality Improvement Plan (QIP) if any of the following occurs:
 - (1). For properly and accurately collected data, accumulated excursions from the range of acceptable operating parameters

**SECTION D. Source Level Requirements**

that determine compliance for this source exceeding two (2) percent duration of the total operating time of the unit in a six (6) month reporting period.

(2). Six excursions from the acceptable operating parameters that determine compliance for this source in a six (6) month reporting period.

(3). The Department determines after reviewing all reported information for this source that the permittee has not responded acceptably to an excursion.

(b). The permittee shall notify the Department if the period for completing the improvements contained in the QIP exceeds 180 days from the date on which the need to implement the QIP was determined.

017 [25 Pa. Code §127.441]**Operating permit terms and conditions.**

[Additional authority for this permit condition is also derived from 40 CFR § 64.8.]

In accordance with 40 CFR § 64.8, the QIP shall include procedures for evaluating the control performance problems. Based on the results of the evaluation procedures, the permittee shall modify the QIP, and provide a copy to the Department, to include procedures for conducting more frequent or improved monitoring in conjunction with one or more of the following:

- (a). Improved preventive maintenance practices.
- (b). Process operation changes.
- (c). Appropriate improvements to control methods.
- (d). Other steps appropriate to correct performance.

018 [25 Pa. Code §127.441]**Operating permit terms and conditions.**

[Additional authority for this permit condition is also derived from 40 CFR § 64.8.]

Following the implementation of a QIP, the Department will require reasonable revisions to the QIP if the plan has failed to either:

- a). Address the cause of the control device performance problem.
- (b). Provide adequate procedures for correcting control device performance problems in an expeditious manner in accordance with good air pollution control practices for minimizing emissions.

019 [25 Pa. Code §127.441]**Operating permit terms and conditions.**

[Additional authority for this permit condition is also derived from 40 CFR § 64.8.]

Implementation of a QIP, shall not excuse the owner or operator of a source from compliance with any existing emission limitation or standard of any existing monitoring, testing, reporting, or recordkeeping requirement that may apply under any federal, state, or local laws or any other applicable requirements under the Clean Air Act.

020 [25 Pa. Code §127.441]**Operating permit terms and conditions.**

The permittee shall perform annually inspections and preventative maintenance of the conservation vent for washer 1101 to keep leakage to a minimum.

VII. ADDITIONAL REQUIREMENTS.**# 021 [25 Pa. Code §127.441]****Operating permit terms and conditions.**

(a). Source ID #203 consists of the following equipment:

- (1). Three Reactors (R1101, R1151, R1171)

**SECTION D. Source Level Requirements**

(2). Three Primary Condensers (C-1101, C-1151, C-1171) - these condensers are used to recover reactants and products from the effluent stream of the reactor for recycle back through the reactor.

(3). Three Secondary Condenser (C-1102, C-1152, C-1172) - these condensers are used to recover reactants and products from the effluent stream of the primary condensers for recycle back through the reactor.

(4) Washer (W-1101)

(b) The exhaust gas from the process equipment (Source ID 203) vents to the Vent Condenser (Source ID C14), before discharging into the atmosphere.

***** Permit Shield in Effect. *****

**SECTION D. Source Level Requirements**

Source ID: 734

Source Name: FIRE PUMP

Source Capacity/Throughput: 1.300 MMBTU/HR

9.300 Gal/HR #2 Oil

Conditions for this source occur in the following groups: GROUP #3

**I. RESTRICTIONS.****Fuel Restriction(s).****# 001 [25 Pa. Code §127.441]****Operating permit terms and conditions.**

No person may, at any time, offer for sale, deliver for use, exchange in trade or permit the use of commercial fuel oil for use in this source contains sulfur in excess of 0.3% by weight.

Operation Hours Restriction(s).**# 002 [25 Pa. Code §127.441]****Operating permit terms and conditions.**

[Additional authority for this permit condition is also derived from 25 Pa. Code §§ 127.511, 127.512(h) and §§ 129.91 - 129.95.]

This source shall not exceed 500 operating hours in any consecutive twelve (12) month rolling period.

II. TESTING REQUIREMENTS.**# 003 [25 Pa. Code §139.16]****Sulfur in fuel oil.**

(a). The following are applicable to the analysis of commercial fuel oil:

(1). The fuel oil sample for chemical analysis shall be collected in a manner that provides a representative sample. Upon the request of a Department official, the person responsible for the operation of the source shall collect the sample employing the procedures and equipment specified in 25 Pa. Code § 139.4(10) (relating to references).

(2). Test methods and procedures for the determination of sulfur shall be those specified in 25 Pa. Code § 139.4(12)--(15).

(b). The requirements in subpart (a), above, shall be waived in the event that a delivery receipt from the supplier, showing the maximum percent sulfur in the fuel, is obtained each time a fuel oil delivery is made.

III. MONITORING REQUIREMENTS.**# 004 [25 Pa. Code §127.441]****Operating permit terms and conditions.**

[Additional authority for this permit condition is also derived from 25 Pa. Code §§ 127.511, 127.512(h) and §§ 129.91 - 129.95.]

An elapsed time meter shall be operated and maintained on this source to indicate cumulative hours operated.

**SECTION D. Source Level Requirements****# 005 [25 Pa. Code §127.441]****Operating permit terms and conditions.**

[Additional authority for this permit condition is also derived from 25 Pa. Code §§ 127.511, 127.512(h) and §§ 129.91 - 129.95.]

The permittee shall monitor the following operating parameters for this source when this source is in operation:

- (a). The number of hours per month that the source has operated.
- (b). The amount of fuel consumed during the month using a Department approved method.

IV. RECORDKEEPING REQUIREMENTS.**# 006 [25 Pa. Code §127.441]****Operating permit terms and conditions.**

[Additional authority for this permit condition is also derived from 25 Pa. Code §§ 127.511, 127.512(h) and §§ 129.91 - 129.95.]

The permittee shall record, in a bound logbook or other method approved by the Department, the following operating parameters for this source when this source is in operation:

- (a). The number of hours that the source has operated on a monthly and a 12-month rolling basis.
- (b). The amount of fuel consumed during the month using a Department approved method.

007 [25 Pa. Code §127.441]**Operating permit terms and conditions.**

For each delivery of No. 2 Fuel for this source, the permittee shall keep records of fuel certifications or the results of testing that demonstrate compliance of the No. 2 Fuel Oil with the applicable limits for the sulfur content for commercial fuel oil.

V. REPORTING REQUIREMENTS.

No additional reporting requirements exist except as provided in other sections of this permit including Section B (Title V General Requirements) and/or Section E (Source Group Restrictions).

VI. WORK PRACTICE REQUIREMENTS.**# 008 [25 Pa. Code §127.441]****Operating permit terms and conditions.**

[Additional authority for this permit condition is also derived from 25 Pa. Code §§ 127.511, 127.512(h) and §§ 129.91 - 129.95.]

This source shall be maintained and operated in accordance with manufacturers specifications. The source shall also be operated and maintained in accordance with good air pollution control practices.

VII. ADDITIONAL REQUIREMENTS.

No additional requirements exist except as provided in other sections of this permit including Section B (Title V General Requirements) and/or Section E (Source Group Restrictions).

***** Permit Shield in Effect. *****

**SECTION D. Source Level Requirements**

Source ID: 735

Source Name: EMERGENCY GENERATOR (DETROIT DIESEL)

Source Capacity/Throughput: 4.600 MMBTU/HR
33.200 Gal/HR #2 Oil

Conditions for this source occur in the following groups: GROUP #3

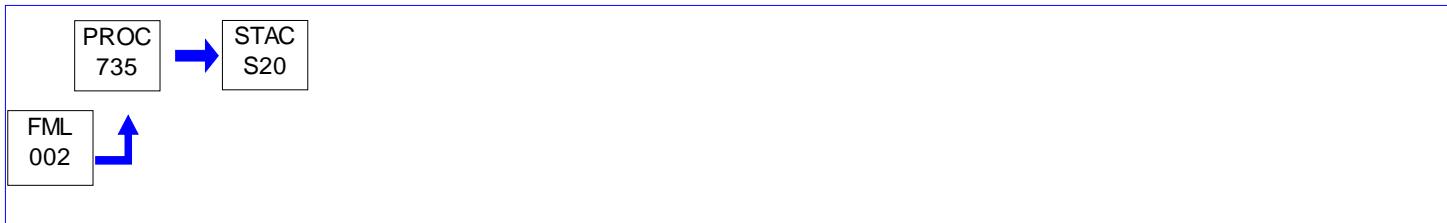
**I. RESTRICTIONS.****Fuel Restriction(s).**

001 [25 Pa. Code §127.441]
Operating permit terms and conditions.

No person may, at any time, offer for sale, deliver for use, exchange in trade or permit the use of commercial fuel oil for use in this source contains sulfur in excess of 0.3% by weight.

Operation Hours Restriction(s).

002 [25 Pa. Code §127.441]
Operating permit terms and conditions.

[Additional authority for this permit condition is also derived from 25 Pa. Code §§ 127.511, 127.512(h) and §§ 129.91 - 129.95.]

This source shall not exceed 500 operating hours in any consecutive twelve (12) month rolling period.

II. TESTING REQUIREMENTS.

003 [25 Pa. Code §139.16]
Sulfur in fuel oil.

(a). The following are applicable to the analysis of commercial fuel oil:

(1). The fuel oil sample for chemical analysis shall be collected in a manner that provides a representative sample. Upon the request of a Department official, the person responsible for the operation of the source shall collect the sample employing the procedures and equipment specified in 25 Pa. Code § 139.4(10) (relating to references).

(2). Test methods and procedures for the determination of sulfur shall be those specified in 25 Pa. Code § 139.4(12)--(15).

(b). The requirements in subpart (a), above, shall be waived in the event that a delivery receipt from the supplier, showing the maximum percent sulfur in the fuel, is obtained each time a fuel oil delivery is made.

III. MONITORING REQUIREMENTS.

004 [25 Pa. Code §127.441]
Operating permit terms and conditions.

[Additional authority for this permit condition is also derived from 25 Pa. Code §§ 127.511, 127.512(h) and §§ 129.91 - 129.95.]

An elapsed time meter shall be operated and maintained on this source to indicate cumulative hours operated.

**SECTION D. Source Level Requirements****# 005 [25 Pa. Code §127.441]****Operating permit terms and conditions.**

[Additional authority for this permit condition is also derived from 25 Pa. Code §§ 127.511, 127.512(h) and §§ 129.91 - 129.95.]

The permittee shall monitor the following operating parameters for this source when this source is in operation:

- (a). The number of hours per month that the source has operated.
- (b). The amount of fuel consumed during the month using a Department approved method.

IV. RECORDKEEPING REQUIREMENTS.**# 006 [25 Pa. Code §127.441]****Operating permit terms and conditions.**

For each delivery of No. 2 Fuel for this source, the permittee shall keep records of fuel certifications or the results of testing that demonstrate compliance of the No. 2 Fuel Oil with the applicable limits for the sulfur content for commercial fuel oil.

007 [25 Pa. Code §127.441]**Operating permit terms and conditions.**

[Additional authority for this permit condition is also derived from 25 Pa. Code §§ 127.511, 127.512(h) and §§ 129.91 - 129.95.]

The permittee shall record, in a bound logbook or other method approved by the Department, the following operating parameters for this source when this source is in operation:

- (a). The number of hours that the source has operated on a monthly and a 12-month rolling basis.
- (b). The amount of fuel consumed during the month using a Department approved method.

V. REPORTING REQUIREMENTS.

No additional reporting requirements exist except as provided in other sections of this permit including Section B (Title V General Requirements) and/or Section E (Source Group Restrictions).

VI. WORK PRACTICE REQUIREMENTS.**# 008 [25 Pa. Code §127.441]****Operating permit terms and conditions.**

[Additional authority for this permit condition is also derived from 25 Pa. Code §§ 127.511, 127.512(h) and §§ 129.91 - 129.95.]

This source shall be maintained and operated in accordance with manufacturers specifications. The source shall also be operated and maintained in accordance with good air pollution control practices.

VII. ADDITIONAL REQUIREMENTS.

No additional requirements exist except as provided in other sections of this permit including Section B (Title V General Requirements) and/or Section E (Source Group Restrictions).

***** Permit Shield in Effect. *****

**SECTION D. Source Level Requirements**

Source ID: 736

Source Name: EMERGENCY GENERATOR (CUMMINS)

Source Capacity/Throughput: 4.400 MMBTU/HR

29.100 Gal/HR #2 Oil

Conditions for this source occur in the following groups: GROUP #3

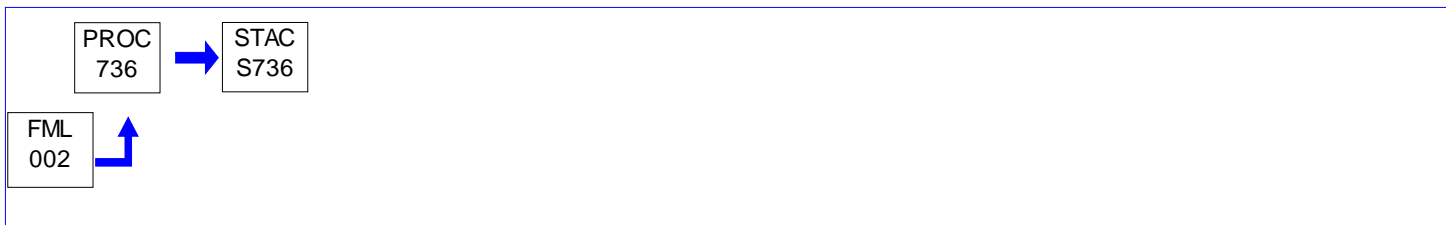
**I. RESTRICTIONS.****Emission Restriction(s).****# 001 [25 Pa. Code §127.441]****Operating permit terms and conditions.**

The operation of this generator shall not exceed the limits listed below for air contaminant emissions:

- (a). Nitrogen Oxides (NO_x) - 13.2 pounds per hour; 0.66 tons per year on a 12-month rolling basis.
- (b). Carbon Monoxide (CO) - 3.8 pounds per hour; 0.19 tons per year on a 12-month rolling basis.
- (c). Volatile Organic Compounds (VOC) - 0.6 pounds per hour; 0.03 tons per year on a 12-month rolling basis.
- (d). Particulate Matter (PM) - 0.4 pounds per hour; 0.02 tons per year on a 12-month rolling basis.
- (e). Sulfur Dioxide (SO₂) - 1.0 pounds per hour; 0.05 tons per year on a 12-month rolling basis.

[Compliance with the particulate matter emission limits and the sulfur dioxide limits in (d) and (e) above also demonstrate compliance with the applicable emission limits of 25 Pa. Code §§ 123.13(c)(1)(i) and 123.21.]

Fuel Restriction(s).**# 002 [25 Pa. Code §127.441]****Operating permit terms and conditions.**

The permittee shall only use No. 2 Fuel Oil in this source.

003 [25 Pa. Code §127.441]**Operating permit terms and conditions.**

No person may, at any time, offer for sale, deliver for use, exchange in trade or permit the use of commercial fuel oil for use in this source contains sulfur in excess of 0.3% by weight.

Operation Hours Restriction(s).**# 004 [25 Pa. Code §127.441]****Operating permit terms and conditions.**

The total operating hours for this source shall not exceed 500 hours in any consecutive 12-month rolling period.

II. TESTING REQUIREMENTS.**# 005 [25 Pa. Code §139.16]****Sulfur in fuel oil.**

- (a). The following are applicable to the analysis of commercial fuel oil:

(1). The fuel oil sample for chemical analysis shall be collected in a manner that provides a representative sample. Upon the request of a Department official, the person responsible for the operation of the source shall collect the sample

**SECTION D. Source Level Requirements**

employing the procedures and equipment specified in 25 Pa. Code § 139.4(10) (relating to references).

(2). Test methods and procedures for the determination of sulfur shall be those specified in 25 Pa. Code § 139.4(12)--(15).

(b). The requirements in subpart (a), above, shall be waived in the event that a delivery receipt from the supplier, showing the maximum percent sulfur in the fuel, is obtained each time a fuel oil delivery is made.

III. MONITORING REQUIREMENTS.**# 006 [25 Pa. Code §127.441]****Operating permit terms and conditions.**

[Additional authority for this permit condition is also derived from 25 Pa. Code §§ 127.511, 127.512(h) and §§ 129.91 - 129.95.]

The permittee shall monitor the following operating parameters for this source when this source is in operation:

- (a). The number of hours per month that the source has operated.
- (b). The amount of fuel consumed during the month using a Department approved method.

IV. RECORDKEEPING REQUIREMENTS.**# 007 [25 Pa. Code §127.441]****Operating permit terms and conditions.**

[Additional authority for this permit condition is also derived from 25 Pa. Code §§ 127.511, 127.512(h) and §§ 129.91 - 129.95.]

The permittee shall record, in a bound logbook or other method approved by the Department, the following operating parameters for this source when this source is in operation:

- (a). The number of hours that the source has operated on a monthly and a 12-month rolling basis.
- (b). The amount of fuel consumed during the month using a Department approved method.
- (c). The permittee shall keep records of the data collected in paragraphs (a) and (b) above for a period of five (5) years, and the records shall be made available to the Department upon request.

008 [25 Pa. Code §127.441]**Operating permit terms and conditions.**

The permittee shall keep records of all inspections and/or maintenance that is performed on this emergency generator. The records shall include, but not be limited to, the following:

- (a). Date of the inspection and/or maintenance.
- (b). Any adjustments that were made to the source.
- (c). Instances of breakdowns.

009 [25 Pa. Code §127.441]**Operating permit terms and conditions.**

For each delivery of No. 2 Fuel for this source, the permittee shall keep records of fuel certifications or the results of testing that demonstrate compliance of the No. 2 Fuel Oil with the applicable limits for the sulfur content for commercial fuel oil.

**SECTION D. Source Level Requirements****V. REPORTING REQUIREMENTS.**

No additional reporting requirements exist except as provided in other sections of this permit including Section B (Title V General Requirements) and/or Section E (Source Group Restrictions).

VI. WORK PRACTICE REQUIREMENTS.

010 [25 Pa. Code §127.441]

Operating permit terms and conditions.

The permittee shall install and maintain an elapsed time meter on this source to indicate cumulative hours operated.

011 [25 Pa. Code §127.441]

Operating permit terms and conditions.

The permittee shall operate and maintain this source in accordance with manufacturer's specifications.

VII. ADDITIONAL REQUIREMENTS.

No additional requirements exist except as provided in other sections of this permit including Section B (Title V General Requirements) and/or Section E (Source Group Restrictions).

***** Permit Shield in Effect. *****

**SECTION D. Source Level Requirements**

Source ID: C930

Source Name: VILTER REFRIGERATED CONDENSER

Source Capacity/Throughput:

N/A

PROCESS GAS

I. RESTRICTIONS.**Emission Restriction(s).****# 001 [25 Pa. Code §127.441]****Operating permit terms and conditions.**

The total post-control toluene emissions from all sources connected to the Vilter Refrigerated Condenser (Source ID C930) shall not exceed 4.5 pounds per operating hour on a monthly average while the Vilter Refrigerated Condenser is operating.

Control Device Efficiency Restriction(s).**# 002 [25 Pa. Code §127.441]****Operating permit terms and conditions.**

The temperature of the exhaust gas leaving the Vilter Refrigerated Condenser (Source ID No. C930) shall be maintained below 10 degrees Fahrenheit as a monthly average when both the sources and the Vilter refrigerated condenser are operating.

II. TESTING REQUIREMENTS.**# 003 [25 Pa. Code §127.441]****Operating permit terms and conditions.**

The permittee shall conduct a stack test to determine the Vilter refrigerated condenser (Source ID No. C930) removal efficiency once per permit term, but no less frequent than once every five (5) years, in accordance with testing requirements specified in Section C of the permit.

III. MONITORING REQUIREMENTS.**# 004 [25 Pa. Code §127.441]****Operating permit terms and conditions.**

(a). The Vilter Refrigerated Condenser (Source ID No. C930) shall be equipped with a temperature monitoring and recording device to continuously measure and record the temperature of the exhaust gas leaving the condenser.

(b). The permittee shall monitor and record the source operating hours with indications that the Vilter Refrigerated Condenser (Source ID No. C930) is or isn't operating.

(c). Compile toluene emissions monthly and on a 12-month rolling sum.

IV. RECORDKEEPING REQUIREMENTS.**# 005 [25 Pa. Code §127.441]****Operating permit terms and conditions.**

(a). The permittee shall keep the following records:

(1). The temperature of the exhaust gas leaving the Vilter refrigerate condenser (Source ID No. C930) on a daily basis and on a monthly average basis.

(2). The toluene emissions on a monthly basis and 12-month rolling sum.

(3). The Vilter refrigerated condenser (Source ID No. C930) operating hours.

(4). The source operating hours with indications of with or without the operation of the Vilter refrigerated condenser (Source ID C930).

(b). The permittee shall use the Department approved methods to calculate the source VOC and HAP emissions with and without the Vilter Refrigerated Condenser (Source ID No. C930) operating, respectively.



SECTION D. Source Level Requirements

V. REPORTING REQUIREMENTS.

No additional reporting requirements exist except as provided in other sections of this permit including Section B (Title V General Requirements).

VI. WORK PRACTICE REQUIREMENTS.

No additional work practice requirements exist except as provided in other sections of this permit including Section B (Title V General Requirements).

VII. ADDITIONAL REQUIREMENTS.

No additional requirements exist except as provided in other sections of this permit including Section B (Title V General Requirements).

***** Permit Shield in Effect. *****

**SECTION E. Source Group Restrictions.**

Group Name: GROUP #1

Group Description: Boilers (B-901, B-902, B-904)

Sources included in this group

ID	Name
031	CLEAVER BROOKS (B-901)
032	CLEAVER BROOKS (B-902)
037	BOILER (B-904)

I. RESTRICTIONS.**Emission Restriction(s).****# 001 [25 Pa. Code §123.11]****Combustion units**

A person may not permit the emission into the outdoor atmosphere of particulate matter from a combustion unit in excess of 0.4 pounds per million Btu of heat input, pursuant to 25 Pa. Code § 123.11(a)(1).

Fuel Restriction(s).**# 002 [25 Pa. Code §123.22]****Combustion units**

No person may, at any time, offer for sale, deliver or use, exchange in trade or permit the use of commercial fuel oil for use in combustion units which contains sulfur in excess of 0.05% by weight, pursuant to 25 Pa. Code § 123.22(e)(2).

Beginning September 1, 2020, the maximum sulfur content in commercial fuel oil shall not exceed by 0.0015% by weight (15 ppm), pursuant to 25 Pa. Code § 123.22(e)(2)(i).

Commercial fuel oil that was stored in this Commonwealth by the ultimate consumer prior to September 1, 2020, which met the applicable maximum allowable sulfur content for commercial fuel oil through August 31, 2020, in subparagraph (i) at the time it was stored, may be used by the ultimate consumer in this Commonwealth on and after September 1, 2020.

003 [25 Pa. Code §127.441]**Operating permit terms and conditions.**

Additional authority for this permit condition is also derived from 25 Pa. Code §§ 127.511, 127.512(h) and §§ 129.91 - 129.95.]

The boiler is to be fired only on gas (natural or LP) or No. 2 fuel oil to which there has been no reclaimed or waste oil or other waste materials added.

II. TESTING REQUIREMENTS.**# 004 [25 Pa. Code §127.441]****Operating permit terms and conditions.**

[Additional authority for this permit condition is also derived from 25 Pa. Code § 139.16.]

(a) The following are applicable to tests for the analysis of commercial fuel oil:

(1) The fuel oil sample for chemical analysis shall be collected in a manner that provides a representative sample. Upon the request of a Department official, the person responsible for the operation of the source shall collect the sample employing the procedures and equipment specified in 25 Pa. Code § 139.4(10) (relating to references).

(2) Tests methods and procedures for the determination of sulfur shall be those specified in 25 Pa. Code § 139.4(12)--(15).

(3) Results shall be reported in accordance with the units specified in 25 Pa. Code § 123.22 (relating to combustion units).

(b) The testing requirements in subpart (a), above, shall be waived in the event that a delivery receipt or invoice from the

**SECTION E. Source Group Restrictions.**

supplier, showing the percent sulfur in the fuel, is obtained each time a fuel oil delivery is made.

III. MONITORING REQUIREMENTS.**# 005 [25 Pa. Code §127.441]****Operating permit terms and conditions.**

[Additional authority for this permit condition is also derived from 25 Pa. Code §§ 127.511 and 127.512(h)]

The permittee shall compile the following using a Department approved method:

- (a) the total monthly and rolling 12 month summation of fuel throughputs, and
- (b) periodic preventive maintenance inspections.

006 [25 Pa. Code §127.441]**Operating permit terms and conditions.**

The permittee shall monitor the following for this source on a monthly basis:

- (a) the amount of each type of fuel consumed using a Department approved method; and,
- (b) the hours of operation.

IV. RECORDKEEPING REQUIREMENTS.**# 007 [25 Pa. Code §127.441]****Operating permit terms and conditions.**

The permittee shall maintain records of the following using a Department approved method:

- (a) the total monthly and rolling 12 month summation of fuel throughputs, and
- (b) periodic preventive maintenance inspections.

008 [25 Pa. Code §127.441]**Operating permit terms and conditions.**

(a). If a delivery receipt or invoice is used to demonstrate compliance with the limits on the sulfur content of the No. 2 Fuel Oil, the permittee shall obtain from the fuel oil supplier, a delivery receipt or invoice that certifies the percentage of sulfur, by weight, is less than or equal to 0.05 percent by weight (500 ppm) , each time a delivery is made. The receipt or invoice shall be maintained on file and made available to the Department upon request.

(b). If the permittee tests samples of the No. 2 Fuel Oil, the permittee shall keep records of the results of the testing for each delivery of No. 2 Fuel Oil to verify that the percentage, by weight, of sulfur in the No. 2 Fuel Oil is less than or equal to 0.05 percent by weight (500 ppm). The results of testing shall be made available to the Department upon request.

[Note: effective September 1, 2020, sulfur in the No. 2 Fuel Oil shall be less than or equal to 0.015 percent by weight (150 ppm)]

009 [25 Pa. Code §127.441]**Operating permit terms and conditions.**

[Additional authority for this permit condition is also derived from 25 Pa. Code §§ 127.511, 127.512(h) and §§ 129.91 - 129.95.]

The permittee shall record, in a bound logbook or other method approved by the Department, the following operating parameters for this source on a monthly basis:

- (a) the amount of each type of fuel consumed using a Department approved method; and,

**SECTION E. Source Group Restrictions.**

(b) the hours of operation.

010 [25 Pa. Code §127.441]**Operating permit terms and conditions.**

[Additional authority for this permit condition is also derived from 40 C.F.R. Part 63 § 63.11225(c)]

The permittee shall keep records of the following:

- a. Copy of each notification and report that was submitted to comply with 40 C.F.R. Part 63 Subpart JJJJJJ.
- b. The date of tune-up for each boiler, the procedures followed for the tune-up, and the manufacturer's specifications to which the boiler was tuned.

V. REPORTING REQUIREMENTS.

No additional reporting requirements exist except as provided in other sections of this permit including Section B (Title V General Requirements).

VI. WORK PRACTICE REQUIREMENTS.**# 011 [25 Pa. Code §127.441]****Operating permit terms and conditions.**

The permittee shall operate and maintain this source in a manner consistent with safety and good air pollution control practices for minimizing emissions and in accordance with the manufacturer's specifications.

[Compliance with this condition assures compliance with 40 C.F.R. 63 § 63.11205(a)]

012 [25 Pa. Code §127.441]**Operating permit terms and conditions.**

[Additional authority for this permit condition is also derived from 40 C.F.R. Part 63 § 63.11223 and § 63.11214(b)]

The permittee shall conduct a biennial performance tune-up for each boiler associated with this source. Each biennial tuneup must be conducted no more than 25 months after the previous tune-up.

013 [25 Pa. Code §127.441]**Operating permit terms and conditions.**

[Additional authority for this permit condition is also derived from 40 C.F.R. Part 63 § 63.11223(b)(1-7)]

The biennial tune-up shall consist of at least the following inspections and requirements for each boiler:

1. Inspect the burner, and clean or replace any components of the burner as necessary, each burner shall be inspected at least once every 36 months.
2. Inspect the flame pattern, as applicable, and adjust the burner as necessary to optimize the flame pattern. The adjustment shall be consistent with the manufacturer's specifications.
3. Inspect the system controlling the air-to-fuel ratio, as applicable, and ensure that it is correctly calibrated and functioning properly.
4. Optimize total emissions of Carbon Monoxide. This optimization should be consistent with the manufacturer's specifications.
5. Measure the concentrations in the effluent stream of carbon monoxide in parts per million (ppm) by volume, and oxygen in volume percent, before and after the adjustments are made.
6. Maintain onsite and submit, if requested by the Administrator, biennial report containing the following:
 - a. The concentrations of CO in the effluent stream in ppm by volume, and oxygen in volume percent, measured before and after the tune-up of each boiler.
 - b. A description of any corrective actions taken as part of the tune-up.
 - c. The type and amount of fuel used over the 12-months prior to the biennial tune-up.
7. If the boiler is not operating on the required date for a tune-up, the tune-up shall be conducted within one week of startup.

014 [25 Pa. Code §127.441]**Operating permit terms and conditions.**

**SECTION E. Source Group Restrictions.**

[Additional authority for this permit condition is also derived from 40 C.F.R. Part 63 § 63.11225(g)]

If the permittee intends to switch fuels, and this fuel switch may result in the applicability of a different subcategory or a switch out of Subpart JJJJJJ due to a switch to 100 percent natural gas, the permittee must provide 30 days prior notice of the date upon which the fuel switch will occur. The notification must identify the following:

1. The name of the owner or operator of the affected source, the location of the source, the boiler(s) that will switch fuels, and the date of the notice.
2. The current applicable subcategory under 40 C.F.R. Part 63 Subpart JJJJJJ.
3. The date on which the permittee becomes subject to the currently applicable standards.
4. The date upon which the permittee will commence the fuel switch.

VII. ADDITIONAL REQUIREMENTS.

No additional requirements exist except as provided in other sections of this permit including Section B (Title V General Requirements).

***** Permit Shield in Effect. *****

**SECTION E. Source Group Restrictions.**

Group Name: GROUP #2

Group Description: Boilers (B-901 and B-902)

Sources included in this group

ID	Name
----	------

No Sources exist for this Group.

I. RESTRICTIONS.**Throughput Restriction(s).**

001 [25 Pa. Code §127.441]

Operating permit terms and conditions.

[Additional authority for this permit condition is also derived from 25 Pa. Code §§ 127.511, 127.512(h) and §§ 129.91-129.95.]

This boiler shall be limited in natural gas usage to 118.13 Million cubic feet on a 12-month rolling basis.

No. 2 fuel shall be used as a back up to the natural gas.

II. TESTING REQUIREMENTS.

No additional testing requirements exist except as provided in other sections of this permit including Section B (Title V General Requirements).

III. MONITORING REQUIREMENTS.

No additional monitoring requirements exist except as provided in other sections of this permit including Section B (Title V General Requirements).

IV. RECORDKEEPING REQUIREMENTS.

No additional record keeping requirements exist except as provided in other sections of this permit including Section B (Title V General Requirements).

V. REPORTING REQUIREMENTS.

No additional reporting requirements exist except as provided in other sections of this permit including Section B (Title V General Requirements).

VI. WORK PRACTICE REQUIREMENTS.

No additional work practice requirements exist except as provided in other sections of this permit including Section B (Title V General Requirements).

VII. ADDITIONAL REQUIREMENTS.

No additional requirements exist except as provided in other sections of this permit including Section B (Title V General Requirements).

***** Permit Shield in Effect. *****

**SECTION E. Source Group Restrictions.**

Group Name: GROUP #3

Group Description: RICE ZZZZ Requirements plus fuel restriction

Sources included in this group

ID	Name
734	FIRE PUMP
735	EMERGENCY GENERATOR (DETROIT DIESEL)
736	EMERGENCY GENERATOR (CUMMINS)

I. RESTRICTIONS.**Fuel Restriction(s).****# 001 [25 Pa. Code §123.22]****Combustion units**

No person may, at any time, offer for sale, deliver for use, exchange in trade or permit the use of commercial fuel oil for use in combustion units in the Southeast Pennsylvania air basin which contains sulfur in excess of 0.2/0.3% by weight, pursuant to 25 Pa. Code § 123.22(e)(2).

Beginning July 1, 2016, the maximum sulfur content in commercial fuel oil shall not exceed 0.05% by weight, except as specified in subparagraphs (ii) and (iii) of 25 Pa. Code § 123.22(e)(2) .

II. TESTING REQUIREMENTS.

No additional testing requirements exist except as provided in other sections of this permit including Section B (Title V General Requirements).

III. MONITORING REQUIREMENTS.

No additional monitoring requirements exist except as provided in other sections of this permit including Section B (Title V General Requirements).

IV. RECORDKEEPING REQUIREMENTS.

No additional record keeping requirements exist except as provided in other sections of this permit including Section B (Title V General Requirements).

V. REPORTING REQUIREMENTS.

No additional reporting requirements exist except as provided in other sections of this permit including Section B (Title V General Requirements).

VI. WORK PRACTICE REQUIREMENTS.

No additional work practice requirements exist except as provided in other sections of this permit including Section B (Title V General Requirements).

VII. ADDITIONAL REQUIREMENTS.**# 002 [25 Pa. Code §127.441]****Operating permit terms and conditions.**

[additional authority is derived from 40 CFR §§63.6603 and 63.6640]

The permittee shall:

- (a). change oil and filter every 500 hours of operation or annually, whichever comes first.
- (b). Inspect air cleaner every 1,000 hours of operation or annually, whichever comes first, and replace as necessary; and
- (c). Inspect all hoses and belts every 500 hours of operation or annually, whichever comes first, and replace as necessary.

*** **Permit Shield in Effect.** ***

**SECTION E. Source Group Restrictions.**

Group Name: GROUP #4

Group Description: Sources without Condenser Requirements

Sources included in this group

ID	Name
115	STRIPPING (S-1101) PAD H
201	ESTERIFICATION - PAD C (R201, R202, R204, R205)
202	ESTERIFICATION - PAD A (R150, R151, R154, R155)

I. RESTRICTIONS.

No additional requirements exist except as provided in other sections of this permit including Section B (Title V General Requirements).

II. TESTING REQUIREMENTS.

No additional testing requirements exist except as provided in other sections of this permit including Section B (Title V General Requirements).

III. MONITORING REQUIREMENTS.**# 001 [25 Pa. Code §127.441]****Operating permit terms and conditions.**

The permittee shall monitor the following for this source on a daily basis when this source is in operation:

- (a). The flow rate of air into this source.
- (b). The temperature of the source.
- (c). Unless otherwise specified for this source in this Title V Permit, the temperature of the gas exiting each condenser connected with this source.

IV. RECORDKEEPING REQUIREMENTS.**# 002 [25 Pa. Code §127.441]****Operating permit terms and conditions.**

(a). The permittee shall keep records of the following for this source on a daily basis when this source is in operation:

- (1). The flow rate of air into this source.
 - (2). The temperature of the source.
 - (3). Unless otherwise specified for this source in this Title V Permit, the temperature of the gas exiting each condenser connected with this source.
- (b). The permittee shall calculate and record VOC emissions from this source on a monthly basis and a 12-month rolling basis.

V. REPORTING REQUIREMENTS.

No additional reporting requirements exist except as provided in other sections of this permit including Section B (Title V General Requirements).

VI. WORK PRACTICE REQUIREMENTS.

No additional work practice requirements exist except as provided in other sections of this permit including Section B (Title V General Requirements).

**SECTION E. Source Group Restrictions.****VII. ADDITIONAL REQUIREMENTS.**

No additional requirements exist except as provided in other sections of this permit including Section B (Title V General Requirements).

***** Permit Shield in Effect. *****

**SECTION E. Source Group Restrictions.**

Group Name: GROUP #5

Group Description: Esterifiers & Strippers

Sources included in this group

ID	Name
111	STRIPPING (S-207) PAD C
112	STRIPPING (S-212) PAD C
115	STRIPPING (S-1101) PAD H
201	ESTERIFICATION - PAD C (R201, R202, R204, R205)
202	ESTERIFICATION - PAD A (R150, R151, R154, R155)
203	ESTERIFICATION - PAD H (R1101, R1151, R1171)

I. RESTRICTIONS.

No additional requirements exist except as provided in other sections of this permit including Section B (Title V General Requirements).

II. TESTING REQUIREMENTS.

No additional testing requirements exist except as provided in other sections of this permit including Section B (Title V General Requirements).

III. MONITORING REQUIREMENTS.

No additional monitoring requirements exist except as provided in other sections of this permit including Section B (Title V General Requirements).

IV. RECORDKEEPING REQUIREMENTS.**# 001 [25 Pa. Code §127.441]****Operating permit terms and conditions.**

[Additional authority for this permit condition is also derived from 25 Pa. Code §§ 127.511, 127.512(h) and §§ 129.91 - 129.95.]

The permittee shall keep records of the condenser's maintenance and repair records. These records shall be maintained on site and be available for the Department to review upon request.

V. REPORTING REQUIREMENTS.

No additional reporting requirements exist except as provided in other sections of this permit including Section B (Title V General Requirements).

VI. WORK PRACTICE REQUIREMENTS.**# 002 [25 Pa. Code §127.441]****Operating permit terms and conditions.**

[Additional authority for this permit condition is also derived from 25 Pa. Code §§ 127.511, 127.512(h) and §§ 129.91 - 129.95.]

The source shall be maintained and operated in accordance with manufacturer's specifications. These sources shall also be operated and maintained in accordance with good air pollution control practices.

VII. ADDITIONAL REQUIREMENTS.

No additional requirements exist except as provided in other sections of this permit including Section B (Title V General Requirements).

***** Permit Shield in Effect. *****



SECTION F. Alternative Operation Requirements.

No Alternative Operations exist for this permit.

**SECTION G. Emission Restriction Summary.**

Source Id	Source Descriptor		
110	STRIPPING/HIVAC ON PAD A		
Emission Limit		Pollutant	
4.500	Lbs/Hr	hourly average basis	Toluene
6.900	Lbs/Hr		VOC
30.200	Tons/Yr	12-month rolling period	VOC
111	STRIPPING (S-207) PAD C		
Emission Limit		Pollutant	
4.500	Lbs/Hr	hourly average basis	Toluene
13.000	Lbs/Hr	hourly average basis	VOC
18.000	Tons/Yr	twelve month rolling basis	VOC
112	STRIPPING (S-212) PAD C		
Emission Limit		Pollutant	
4.500	Lbs/Hr	hourly average basis	Toluene
10.000	Lbs/Hr	hourly average basis	VOC
35.200	Tons/Yr	twelve month rolling basis	VOC
115	STRIPPING (S-1101) PAD H		
Emission Limit		Pollutant	
4.500	Lbs/Hr	hourly average basis	Toluene
201	ESTERIFICATION - PAD C (R201, R202, R204, R205)		
Emission Limit		Pollutant	
16.000	Tons/Yr	12-month rolling sum period	VOC
202	ESTERIFICATION - PAD A (R150, R151, R154, R155)		
Emission Limit		Pollutant	
18.500	Tons/Yr	twelve month rolling basis	VOC
203	ESTERIFICATION - PAD H (R1101, R1151, R1171)		
Emission Limit		Pollutant	
8.860	Tons/Yr	12-month rolling sum period	VOC
736	EMERGENCY GENERATOR (CUMMINS)		
Emission Limit		Pollutant	
0.190	Tons/Yr	12-month rolling basis	CO
3.800	Lbs/Hr		CO
0.660	Tons/Yr	12-month rolling basis	NOX
13.200	Lbs/Hr		NOX
0.050	Tons/Yr	112-month rolling basis	SOX
1.000	Lbs/Hr		SOX
0.020	Tons/Yr	12-month rolling basis	TSP
0.400	Lbs/Hr		TSP
0.030	Tons/Yr	12-month rolling basis	VOC

**SECTION G. Emission Restriction Summary.**

Source Id	Source Description
0.600	Lbs/Hr VOC
C930	VILTER REFRIGERATED CONDENSER
Emission Limit	Pollutant
4.500 Lbs/Hr	Toluene

Site Emission Restriction Summary

Emission Limit		Pollutant
49.900 Tons/Yr	12-month rolling sum basis	VOC
25.000 Tons/Yr	less than this limit on a 12-month rolling sum basis	NOX
9.990 Tons/Yr	single HAP; 12-month rolling sum basis	Hazardous Air Pollutants
24.990 Tons/Yr	combined HAPs; 12-month rolling sum basis	Hazardous Air Pollutants

**SECTION H. Miscellaneous.**

(a). The Department has determined that the emissions from the following activities, excluding those indicated as site level requirements, in Section C, of this permit, do not require additional limitations, monitoring, or recordkeeping:

- (1). Space heaters.
- (2). Machine shop and maintenance shop equipments.
- (3). Plant maintenance and upkeep.
- (4). Raw material storage tanks (tanks not previously listed in Section D under Source ID No. 900).
- (5). In-process tanks (tanks not previously listed in Section D under Source ID No. 900).
- (6). Hazardous waste system (tanks not previously listed in Section D under Source ID No. 900).
- (7). Pilot plant.
- (8). Non-hazardous wastewater pre-treatment system.
- (9). Hoods.

(b). The permittee shall provide documentation and/or calculations to the Department to verify that the sources listed in paragraph (a) above are considered insignificant sources of emissions. The permittee shall also include emissions from the sources listed in paragraph (a) above in their AIMS Reports.

(c). For the purpose of this permit, Source 118, "Multiple Washers", is comprised of the following five washers: washers 152, 162, 203, and 211.

(d). The capacities for material and fuel that are listed in Sections A and D of this permit are used for descriptive purposes. These capacities are not considered limitations or enforceable conditions by the Department.

(e). The permit OP-15-0015 serves as a basis for certain terms and conditions written in this permit.

(f). This Title V Permit has been revised on December 2, 2002 for settlement of certain appeal issues. Among the items changed in this permit are the use of abbreviations to the list of condensers, addition of No. 2 Fuel Oil as an FML for Source ID No. 033, "media approved by the Department" replaced "permanent written log" in Section C Condition #010, the total amount of natural gas fired in Source ID Nos. 031 and 032 in Section D was changed from 118.13 MMcf/yr for the combined emissions from both boilers to 118.13 MMcf/yr for each boiler, the frequency of monitoring and recording for the boilers were changed from daily to weekly, and the word "multiple" was included in Sections A and D for the Washers (Source ID No. 118).

(g). APS No. 345475; Authorization No. 508088. This Title V Permit has been revised for settlement of appeal issues. The changes include the condenser stack testing requirement for each reactor and stripper listed in the permit; the classification of items (4) - (9) in paragraph (a) above, items formerly under Miscellaneous VOC Sources (Source ID No. 119), as insignificant activities; and the creation of Source ID No. 900 [Storage Tanks (Vapor Press > 1.5 psia)], which denotes which storage tanks are regulated by 25 Pa. Code § 129.57.

(h). APS No. 345475; Authorization No. 635623; This action applies to the renewal of the Title V Permit for Sartomer Company, Inc. This renewal addresses CAM for Source ID Nos. 104, 110, 112, 114, 115, 116, 153, 191, and 709. This renewal also incorporates the requirements of plan approval/operating permit PA-15-0015B for a 605 bhp Cummins Emergency Generator (Source ID No. 736). Revisions were made to address the change in the Department's address and contact information, additions of record keeping for any testing that is performed on No. 2 Fuel Oil, and an addition of record keeping for facility-wide monitoring of odors, visible emissions, and particulate matter.

(i). November 23, 2009, AUTH ID 815534, Request to amend TVOP to incorporate Plan Approval No. 15-0015C.

(j). APS No. 710689; Authorization ID No. 819478: The Title V Permit was revised for a change of ownership in accordance with the requirements of 25 Pa. Code Section 127.450.

(k) APS No. 834706; Authorization No. 1029039: Renewal of Title V Permit

Changes to Section A

1. Source ID Nos. 033 (Boiler B-903) was decommissioned and replaced with source 37 (Boiler B-904 – a 9.85 MM BTU input boiler). The replacement boiler was verified during the FCE inspection conducted on June 6, 2014.
2. Source 201 (Pad C Reactors) – see Section D changes.
3. Source 202 (Pad A Reactors) – see Section D changes.
4. Source 203 (Pad H Reactors) – see Section D changes.

**SECTION H. Miscellaneous.**

Changes to Section C

The following conditions were updated:

1. Condition #002 pertaining to the prohibition of certain fugitive emissions,
2. Condition #003 pertaining to fugitive particulate matter,
3. Condition #009 pertaining to open burning operations,

A compliance schedule was added to ensure that testing is completed by June 1, 2016.

Changes to Section D

Source ID Nos. 31,32,37 (all Boilers)

1. Added new recordkeeping and work practice conditions (#012, 014, 015, 016) to ensure compliance with 40 C.F.R. Part 63 Subpart JJJJJ.
2. Added fuel restriction (conditions #002) to limit sulfur content of No.2 fuel to 0.05 percent by weight (500 ppm) effective July 1, 2016.

Sources ID Nos. 102,103,104 and 191 (Pad C Reactors)

The reactors (R201, R202, R204, R205) located on Pad C share a common Secondary Condenser (C-203) and vent thru a common stack (S01). These sources all have the same conditions and were combined under one source (Source 201)

Sources ID Nos. 105, 106, 107 and 108 (Pad A Reactors)

The reactors (R150, R151, R154, R155) located on Pad A share a common Secondary Condenser (C-162) and vent thru a common stack (S05). These sources all have the same conditions and were combined under one source (Source 202).

Sources ID Nos. 114, 116, and 120 (Pad H Reactors)

The reactors (R1101, R1151, R1171) located on Pad H share a common Tertiary Condenser (C-1106) and vent thru a common stack (S14). These sources all have the same conditions and were combined under one source (Source 203).

Sources ID Nos. 110, 111, 112, 115, 153 and 709 (Strippers for Pads A, B and C)

Moved conditions that related to operation without the Vilter operating to Additional conditions to help clarify when these conditions are relevant.

Sources ID Nos. 31, 032, and 037

All three boilers are subject to subpart JJJJJ. Group conditions were added to for the boilers to comply with this subpart.

Sources ID Nos. 734, 735 and 736

Group conditions for the fire pump engine and both emergency generator engines were added to the permit to comply with subpart ZZZZ.

This renewal incorporates Plan Approval 15-0015E.

(l) APS No. 834706:Authorization No. 1155831: Minor Modification - Facility wide VOC limit incorporated into Section C, condition #008.

(m) APS No. 834706:Authorization 1260706: Amendment to add testing conditions - Section C, conditions #011 and #012.

**SECTION H. Miscellaneous.**

n) APS No. 834706:Authorization 1298127: TVOP renewal. RFDs 4925, 5228 and 5604 incorporated into TVOP. Source ID Nos. 125 and 900 were removed from source list .



***** End of Report *****
